

M-Class™ *Mark II*

Peel & Present Option ■■■

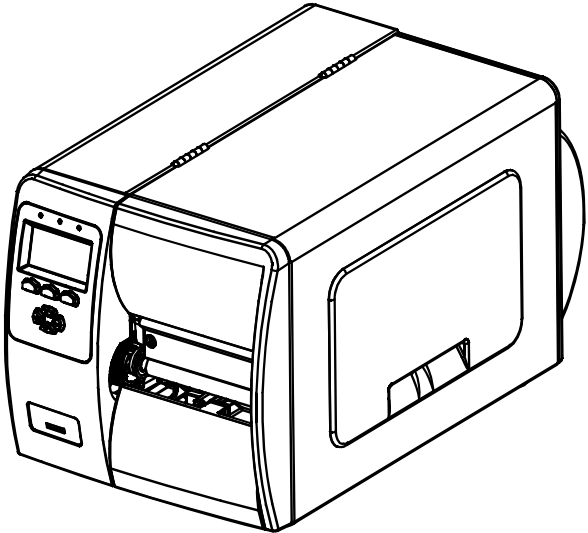

right by our customers. ■■■

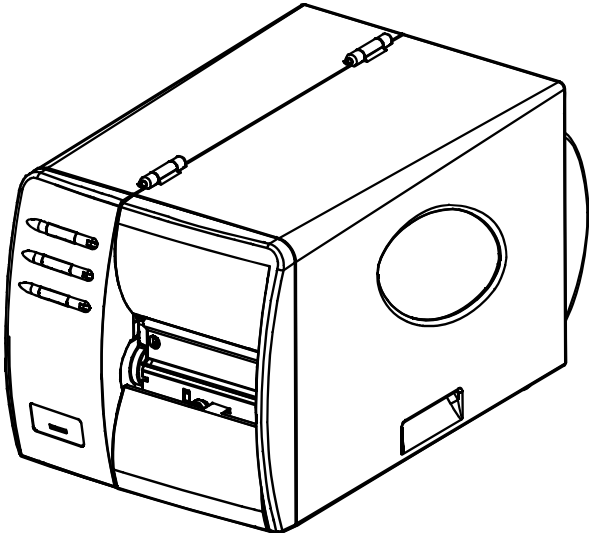

datamax·o'neil

Contents of the Peel & Present Kit

This kit contains the following items:

Peel and Present Mechanism

Assist Roller and Bushing

NOTE: If this option was ordered with the printer the Assist Roller and Bushing will already be installed in the printer. Proceed to *Step 3: Installing the Peel & Present Mechanism*. Otherwise follow the steps below to install these items into the printer.

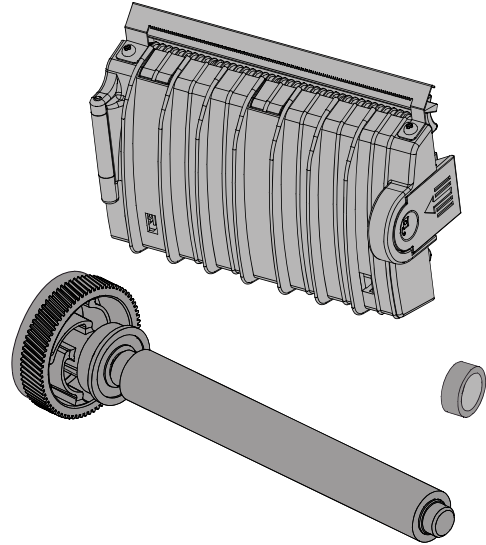

Other Requirements

This option requires the Internal Rewinder option. Contact your sales representative for more information.

Tools Required

To install this option you will need a #2 Flathead and a #2 Phillips head screwdriver.

Step 1: Preparing the Printer

- 1 Turn 'Off' the power switch and unplug the printer.
- 2 Open the cover. Press in Latch and raise the Printhead Mechanism.
- 3 Remove any media from the printer.
- 4 Remove the Fascia by gently pulling it forward.
- 5 Loosen and remove the Thumbscrew, then remove the Tear Plate.

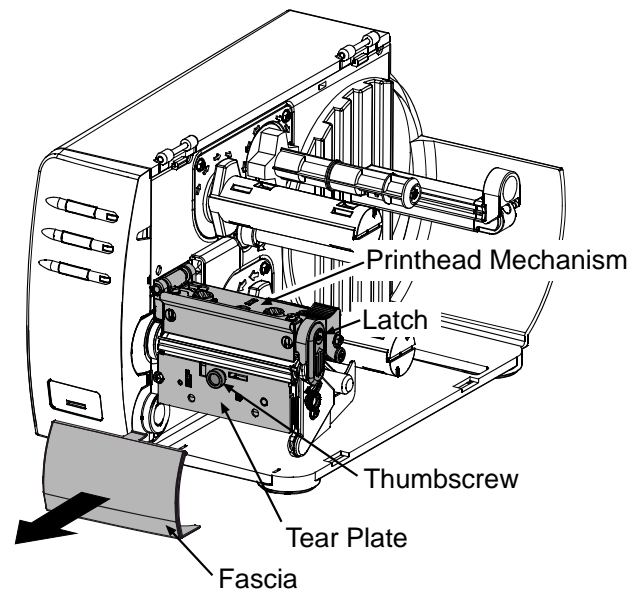

- Using a #2 Philips head screwdriver, remove the Screw that secures the Side Plate to the printer.

- Remove the Side Plate.

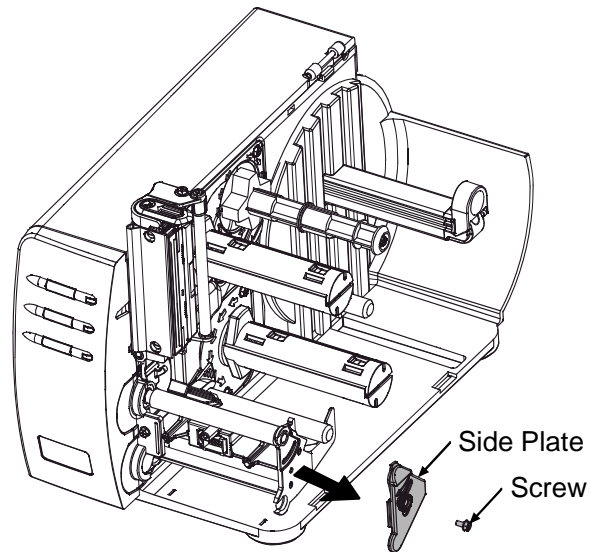

- Using a #2 Philips head screwdriver, remove the Screw that secures the Bearing Cap to the printer.

- Remove the Bearing Cap and the Hole Plug.

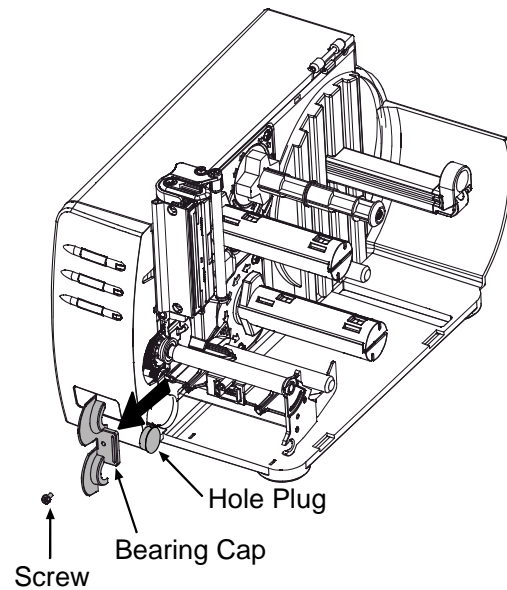

Step 2: Installing the Assist Roller

- Insert the Assist Roller, as shown, gears first into the printer.

- Pivot the other end of the roller into the Bearing Block.

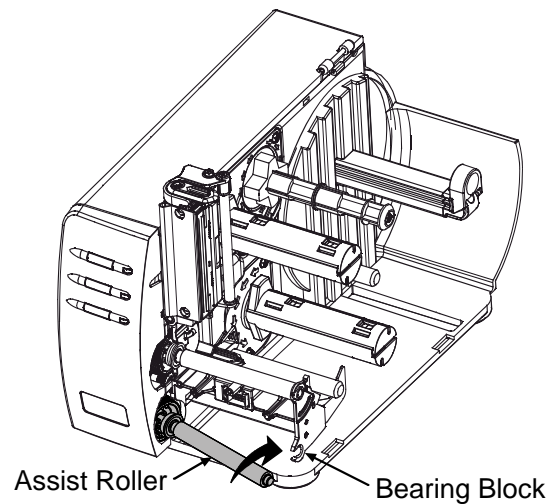

- ③ Insert the Bushing completely into the Bearing Block.

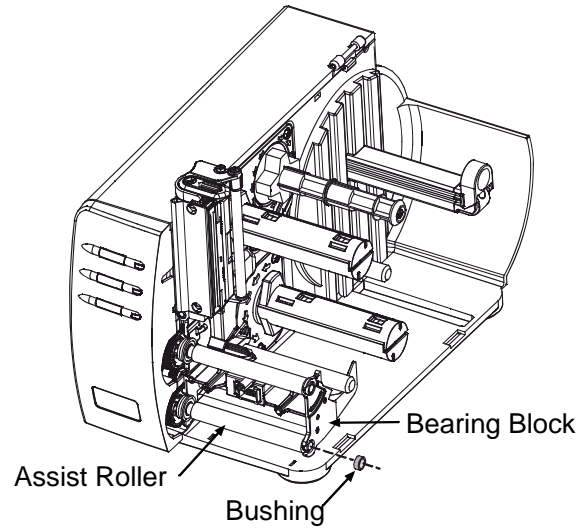

- ④ While holding the Assist Roller Bearing against the Centerplate, replace the Bearing Cap.

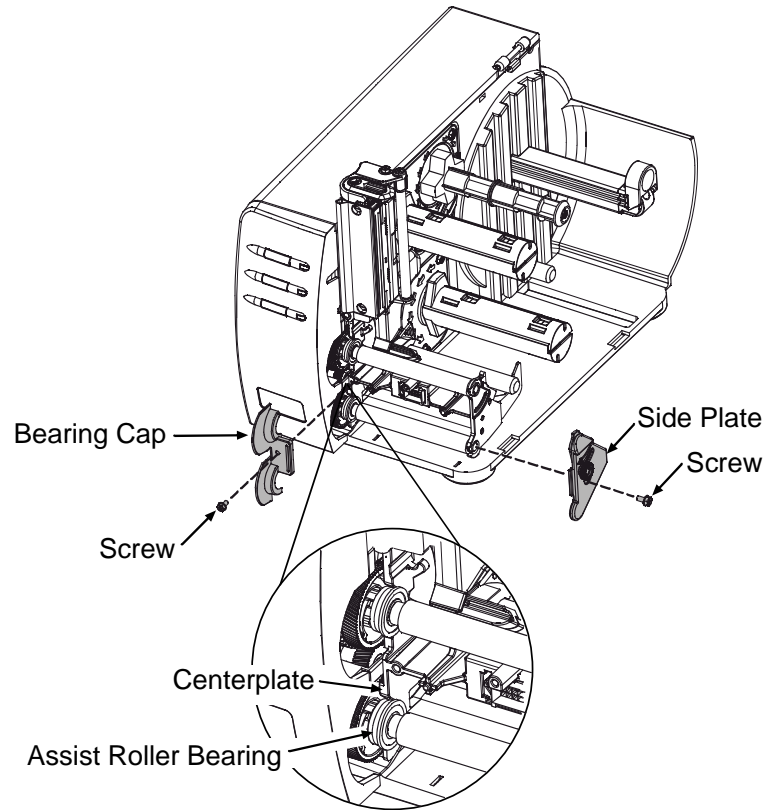

- ⑤ Hold the Bearing Cap in place and secure it with the Screw.

- ⑥ Replace the Side Plate and start, but do not tighten the Screw.

- 7 Ensure that the Leveling Cam is loose, and then close and latch the Printhead Assembly.

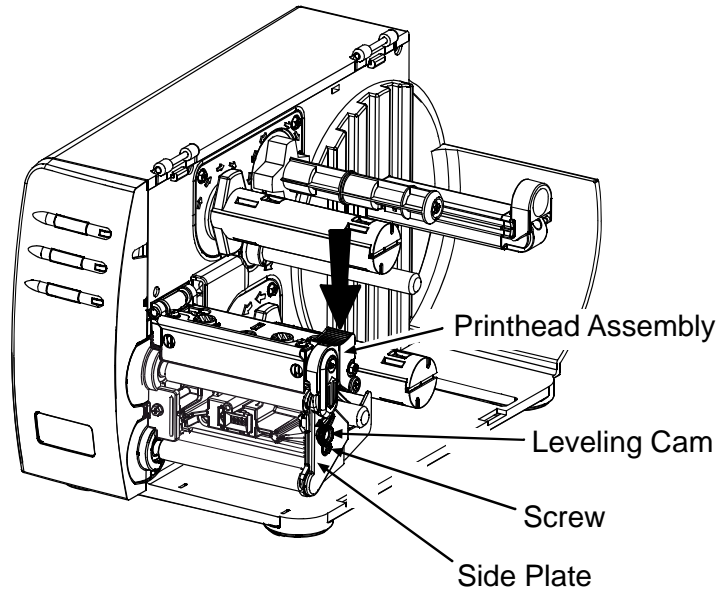

- 8 While pushing down on the Printhead Assembly, as shown, pull down on the Side Plate and tighten the Screw.

Verify Latch Operation:

- Open and close the printhead assembly, verify that the latch is fully engaged. If you are unable to get the printhead to latch, the side plate is too low.
- Pressing down on the printhead assembly should not cause the latch to loosen or reveal any gap at the latch point. If there is a gap or movement in the latch then the side plate is too high.
- Print some sample labels. If degraded print quality or ribbon tracking problems are observed then the side plate is not positioned correctly.

Step 3: Installing the Peel & Present Mechanism

- 1 Position the Peel and Present Mechanism for mounting on the front of the printer.
- 2 Tighten the Mounting Screw to secure the mechanism to the printer.

This completes the installation process.

Proceed to Loading Media to begin use.

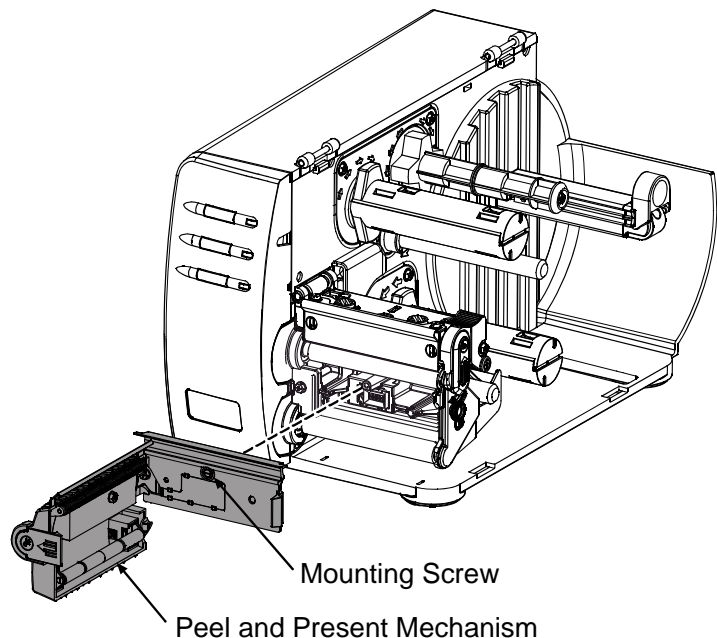

Loading Media

With the Peel and Present option, labels printed in a batch will be automatically be separated from the backing material and dispensed “on-demand”– that is, printing will occur only after a previously printed label has been removed from the printer.

- 1 Press in the Latch to open the mechanism.

- 2 Swing the mechanism open.

- 3 Load the printer with media (see the *Operator’s Manual* for detailed instructions).

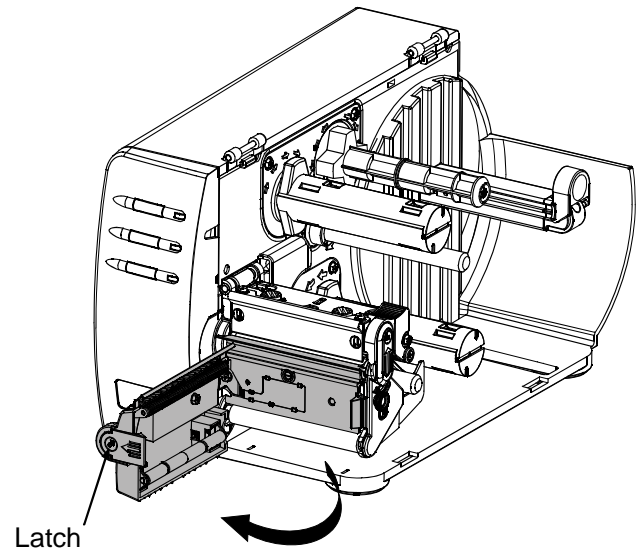

- 4 Load media into the printer as you normally would for tear-off operation (see the *Operator’s Manual* for details), however, extend an additional 12 inches (30 cm) of media out the front of the printer.

- 5 From this 12 inches (30 cm) of media, remove all of the labels, so that only the Backing Material remains.

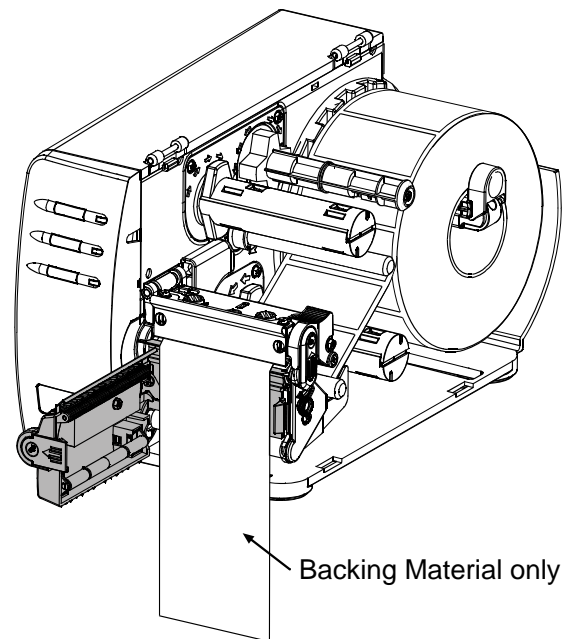

- ⑥ Route the Backing Material under the Assist Roller and around the Internal Rewinder, as shown below.

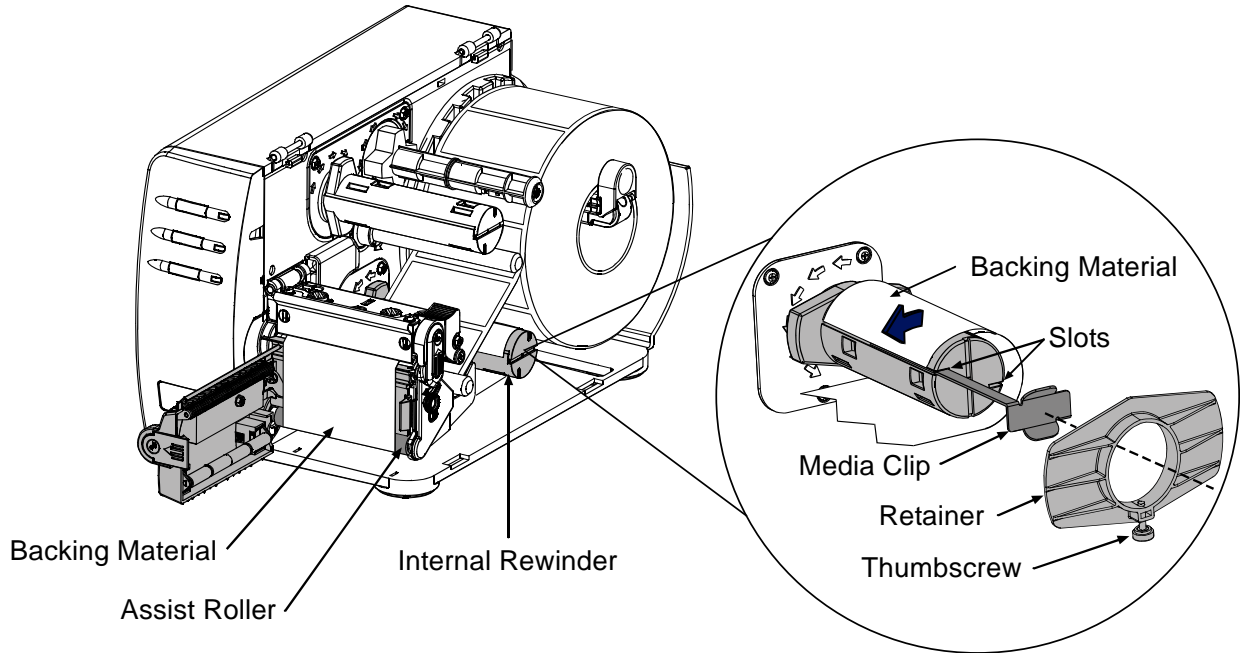

Note: The Media Retainer can be used in place of the Media Clip for a more consistent rewind roll. The Media Clip and Media Retainer cannot be used together.

- ⑦ Put the leading edge of the Media into a Slot on the Internal Rewinder and insert the Media Clip. Be sure the leading edge of the Media is cut square and that is inserted evenly into the slot.
- ⑧ Manually rotate the Internal Rewinder to remove slack from the Media.
- ⑨ Plug in and turn ‘On’ the printer. After initialization, press the FEED Button to align the next label to the top of form position. (If a peeled label is presented, remove it to proceed.) The printer is now ready for on-demand use.

Setup, Configuration, and Operation

The Peel and Present option is plug and play; no setup or configuration is required. As soon as power is applied, the printer senses and enables the Present Sensor for operation.

During operation, when a label is present (blocking the sensor), the yellow Stop Light on the front panel of the printer will flash to prompt you that a label awaits removal.

With printers equipped with an LCD display, the display will read “REMOVE LABEL”

☑ Notes: (1) The operation of the Present Sensor can also be controlled via software commands from the host. Be sure that your software program is properly configured for use with this option. (2) If the Present Sensor is disconnected without first powering off the printer, the printer will behave as if there is a label blocking the sensor. Turn the printer off and then back on. The printer will reconfigure itself to operate without the Present Option

Unloading the Internal Rewinder

When the Internal Rewinder becomes full remove the Media Clip. Grasp the used backing material and pull it from the Internal Rewinder.

☑ Note: Never allow the outer diameter of backing material to exceed 4 inches (102 mm) on the Internal Rewinder.

Periodic Maintenance

The Peel Mechanism Rollers will need to be disassembled and cleaned approximately every 100,000 inches to ensure trouble free operation. This cleaning interval may be more or less depending on the type of adhesive on the back of your media. Heavy or “gummy” adhesive will require more frequent cleaning.

Upper Rollers:

- ❶ Remove the Peel Mechanism from the printer. Press in on the Latch and allow the Front Cover to swing open.
- ❷ Remove the small C-Clip from the Upper Roller Shaft.

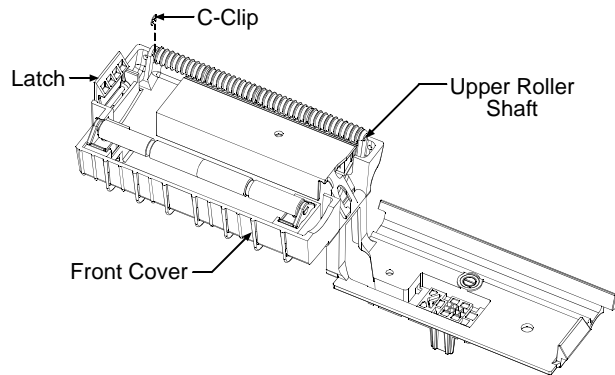

- ③ Remove Upper Roller Shaft and associated Rollers.
- ④ Clean all surfaces of the Rollers and the Upper Roller Shaft. Isopropyl Alcohol can be used, for heavy or stubborn deposits WD-40 or an adhesive remover can be used. Be sure all the ridges on the rollers are free of debris.
- ⑤ Re-assemble the Upper Roller Shaft, Rollers, and C-Clip into the Peel Mechanism Assembly.

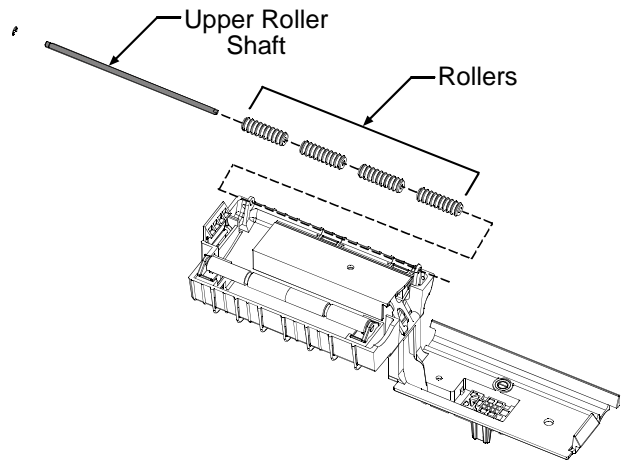

Lower Rollers:

- ① Remove the Peel Mechanism from the printer. Press in on the Latch and allow the Front Cover to swing open.
- ② Push in on the Tab as shown, repeat for the other side and then remove the entire Lower Roller Assembly.

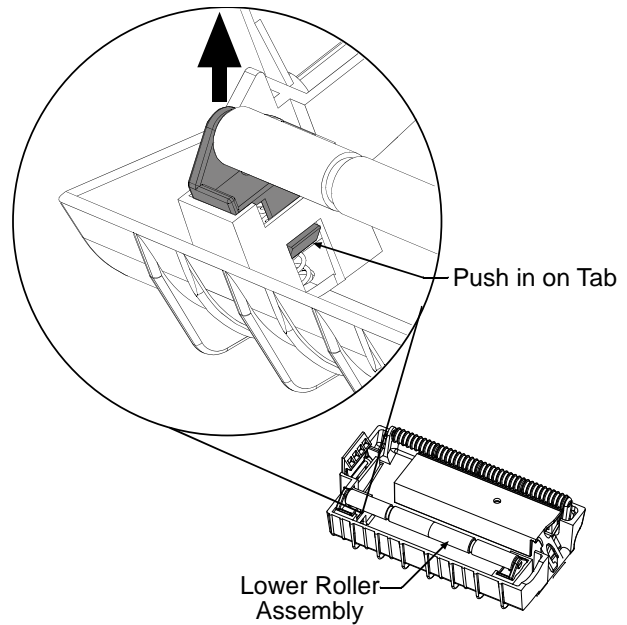

- ③ Remove Lower Roller Shaft and associated Rollers. Note the order of the Rollers as they are removed, they must be re-installed in the same order.
- ④ Clean all surfaces of the Rollers and the Lower Roller Shaft. Isopropyl Alcohol can be used, for heavy or stubborn deposits WD-40 or an adhesive remover can be used. Be sure all the ridges on the rollers are free of debris.
- ⑤ Re-assemble the Lower Roller Shaft and Rollers. Reinstall the assembly into the Peel Mechanism Assembly

