

# Magellan™ 8300/8400



**Technical Guide**

## **Datalogic Scanning, Inc.**

959 Terry Street

Eugene, Oregon 97402

USA

Telephone: (541) 683-5700

Fax: (541) 345-7140

An Unpublished Work - All rights reserved. No part of the contents of this documentation or the procedures described therein may be reproduced or transmitted in any form or by any means without prior written permission of Datalogic Scanning, Inc. or its subsidiaries or affiliates ("Datalogic" or "Datalogic Scanning"). Owners of Datalogic products are hereby granted a non-exclusive, revocable license to reproduce and transmit this documentation for the purchaser's own internal business purposes. Purchaser shall not remove or alter any proprietary notices, including copyright notices, contained in this documentation and shall ensure that all notices appear on any reproductions of the documentation.

Should future revisions of this manual be published, you can acquire printed versions by contacting your Datalogic representative. Electronic versions may either be downloadable from the Datalogic website ([www.scanning.datalogic.com](http://www.scanning.datalogic.com)) or provided on appropriate media. If you visit our website and would like to make comments or suggestions about this or other Datalogic publications, please let us know via the "Contact Datalogic" page.

### **Disclaimer**

Datalogic has taken reasonable measures to provide information in this manual that is complete and accurate, however, Datalogic reserves the right to change any specification at any time without prior notice.

Datalogic and the Datalogic logo are registered trademarks of Datalogic S.p.A. in many countries, including the U.S.A. and the E.U. All other brand and product names may be trademarks of their respective owners.

This product may be covered by one or more of the following patents: 4603262 • 4639606 • 4652750 • 4672215 • 4699447 • 4709369 • 4749879 • 4786798 • 4792666 • 4794240 • 4798943 • 4799164 • 4820911 • 4845349 • 4861972 • 4861973 • 4866257 • 4868836 • 4879456 • 4939355 • 4939356 • 4943127 • 4963719 • 4971176 • 4971177 • 4991692 • 5001406 • 5015831 • 5019697 • 5019698 • 5086879 • 5115120 • 5144118 • 5146463 • 5179270 • 5198649 • 5200597 • 5202784 • 5208449 • 5210397 • 5212371 • 5212372 • 5214270 • 5229590 • 5231293 • 5232185 • 5233169 • 5235168 • 5237161 • 5237162 • 5239165 • 5247161 • 5256864 • 5258604 • 5258699 • 5260554 • 5274219 • 5296689 • 5298728 • 5311000 • 5327451 • 5329103 • 5330370 • 5347113 • 5347121 • 5371361 • 5382783 • 5386105 • 5389917 • 5410108 • 5420410 • 5422472 • 5426507 • 5438187 • 5440110 • 5440111 • 5446271 • 5446749 • 5448050 • 5463211 • 5475206 • 5475207 • 5479011 • 5481098 • 5491328 • 5493108 • 5504350 • 5508505 • 5512740 • 5541397 • 5552593 • 5557095 • 5563402 • 5565668 • 5576531 • 5581707 • 5594231 • 5594441 • 5598070 • 5602376 • 5608201 • 5608399 • 5612529 • 5629510 • 5635699 • 5641958 • 5646391 • 5661435 • 5664231 • 5666045 • 5671374 • 5675138 • 5682028 • 5686716 • 5696370 • 5703347 • 5705802 • 5714750 • 5717194 • 5723852 • 5750976 • 5767502 • 5770847 • 5786581 • 5786585 • 5787103 • 5789732 • 5796222 • 5804809 • 5814803 • 5814804 • 5821721 • 5822343 • 5825009 • 5834708 • 5834750 • 5837983 • 5837988 • 5852286 • 5864129 • 5869827 • 5874722 • 5883370 • 5905249 • 5907147 • 5923023 • 5925868 • 5929421 • 5945670 • 5959284 • 5962838 • 5979769 • 6000619 • 6006991 • 6012639 • 6016135 • 6024284 • 6041374 • 6042012 • 6045044 • 6047889 • 6047894 • 6056198 • 6065676 • 6069696 • 6073849 • 6073851 • 6094288 • 6112993 • 6129279 • 6129282 • 6134039 • 6142376 • 6152368 • 6152372 • 6155488 • 6166375 • 6169614 • 6173894 • 6176429 • 6188500 • 6189784 • 6213397 • 6223986 • 6230975 • 6230976 • 6244510 • 6259545 • 6260763 • 6266175 • 6273336 • 6276605 • 6279829 • 6290134 • 6290135 • 6293467 • 6303927 • 6311895 • 6318634 • 6328216 • 6332576 • 6332577 • 6343741 • 6454168 • 6478224 • 6568598 • 6578765 • 6705527 • 6857567 • 6974084 • 6991169 • 7051940 • 7170414 • 7172123 • 7201322 • 7204422 • 7215493 • 7224540 • 7234641 • 7243850 • 7374092 • 7407096 • 7490770 • 7495564 • 7506816 • 7527198 • 7527207 • 7537166 • 7562817 • 601 26 118.6 • AU703547 • D312631 • D313590 • D320011 • D320012 • D323492 • D330707 • D330708 • D349109 • D350127 • D350735 • D351149 • D351150 • D352936 • D352937 • D352938 • D352939 • D358588 • D361565 • D372234 • D374630 • D374869 • D375493 • D376357 • D377345 • D377346 • D377347 • D377348 • D388075 • D446524 • D606544 • EP0256296 • EP0260155 • EP0260156 • EP0295936 • EP0325469 • EP0349770 • EP0368254 • EP0442215 • EP0498366 • EP0531645 • EP0663643 • EP0698251 • EP01330772 • EP870761 • GB2252333 • GB2284086 • GB2301691 • GB2304954 • GB2307093 • GB2308267 • GB2308678 • GB2319103 • GB2333163 • GB2343079 • GB2344486 • GB2345568 • GB2354340 • ISR107546 • ISR118507 • ISR118508 • JP1962823 • JP1971216 • JP2513442 • JP2732459 • JP2829331 • JP2953593 • JP2964278 • MEX185552 • MEX187245 • RE37166 • RE40071 • Other Patents Pending





# Table of Contents

<b>Chapter 1. Introduction .....</b>	<b>1-1</b>
Technical Support .....	1-1
Datalogic Website Support .....	1-1
Reseller Technical Support .....	1-1
Telephone Technical Support .....	1-1
.....	1-2
Scanner and Scanner/Scale Nomenclature .....	1-2
Connections .....	1-3
Weighing .....	1-4
Warm-Up Time .....	1-5
Electrical Specifications .....	1-6
Power Supply .....	1-7
Agency Compliances .....	1-8
<b>Chapter 2. Site Preparation and Installation.....</b>	<b>2-1</b>
Models .....	2-1
Pre-Installation Considerations .....	2-3
Checkstand Design .....	2-3
Scanner Installation .....	2-4
Scanner Maintenance .....	2-4
Scanner Usage .....	2-5
Site Preparation Overview .....	2-5
Ventilation and Spacing .....	2-7
Power Installation .....	2-9
Grounding .....	2-9
Liquid Spills and Moisture .....	2-10
Counter Cutout .....	2-10
Installation Overview .....	2-17
Unpacking .....	2-17
Scale Diagnostic Mode .....	2-19
Cables & Connections .....	2-19
Remote Scale Display Placement/Installation .....	2-20
Lighting Considerations .....	2-20
Viewing Angle .....	2-21
Remote Display Cabling .....	2-22
Placing and Installing the Remote Scale Display .....	2-22
Set-Up & Installation .....	2-25
Set-up .....	2-25
Installation .....	2-27
<b>Chapter 3. Problem Isolation.....</b>	<b>3-1</b>
Diagnostic Procedures .....	3-2
Error Codes .....	3-3

---

Scale Error Reporting .....	3-6
<b>Chapter 4. Calibration .....</b>	<b>4-1</b>
Description of Calibration Sequence .....	4-2
Motion Test .....	4-3
Preparing the Scanner/Scale for Calibration .....	4-4
Calibrating the Scale .....	4-4
Calibration Verification (Kilograms) .....	4-7
Increasing-Load Test (Phase 1) .....	4-7
Shift Test (Metric) .....	4-8
Increasing- Load Test (Phase 2) .....	4-9
Blanking Test .....	4-10
Decreasing-Load Test .....	4-11
Return to Zero Test .....	4-11
<b>Chapter 5. Programming .....</b>	<b>5-1</b>
Entering and Exiting Programming Mode. ....	5-1
Return to Factory Settings .....	5-2
Scale Features .....	5-3
Scale Enable .....	5-3
Scale Enforced Zero Return .....	5-4
Scale Interface Type .....	5-7
Scale Calibration Notification .....	5-9
Scale Intercharacter Delay .....	5-10
Remote Display — Enable/Disable .....	5-11
Interface Related Features .....	5-12
Interface Type .....	5-12
<b>Appendix A. Keypad .....</b>	<b>A-1</b>

# Chapter 1

# Introduction

---

## Technical Support

### Datalogic Website Support

The Datalogic website ([www.scanning.datalogic.com](http://www.scanning.datalogic.com)) is the complete source for technical support and information for Datalogic products. The site offers product support, product registration, warranty information, product manuals, product tech notes, software updates, demos, and instructions for returning products for repair.

### Reseller Technical Support

An excellent source for technical assistance and information is an authorized Datalogic reseller. A reseller is acquainted with specific types of businesses, application software, and computer systems and can provide individualized assistance.

### Telephone Technical Support

If you do not have internet or email access, you may contact Datalogic technical support at (541) 349-8283 or check the back cover of your manual for more contact information.

# Scanner and Scanner/Scale Nomenclature

Controls, indicators and other nomenclature are shown in Figure 1-1.

**Figure 1-1. Scanner/Scale Nomenclature**

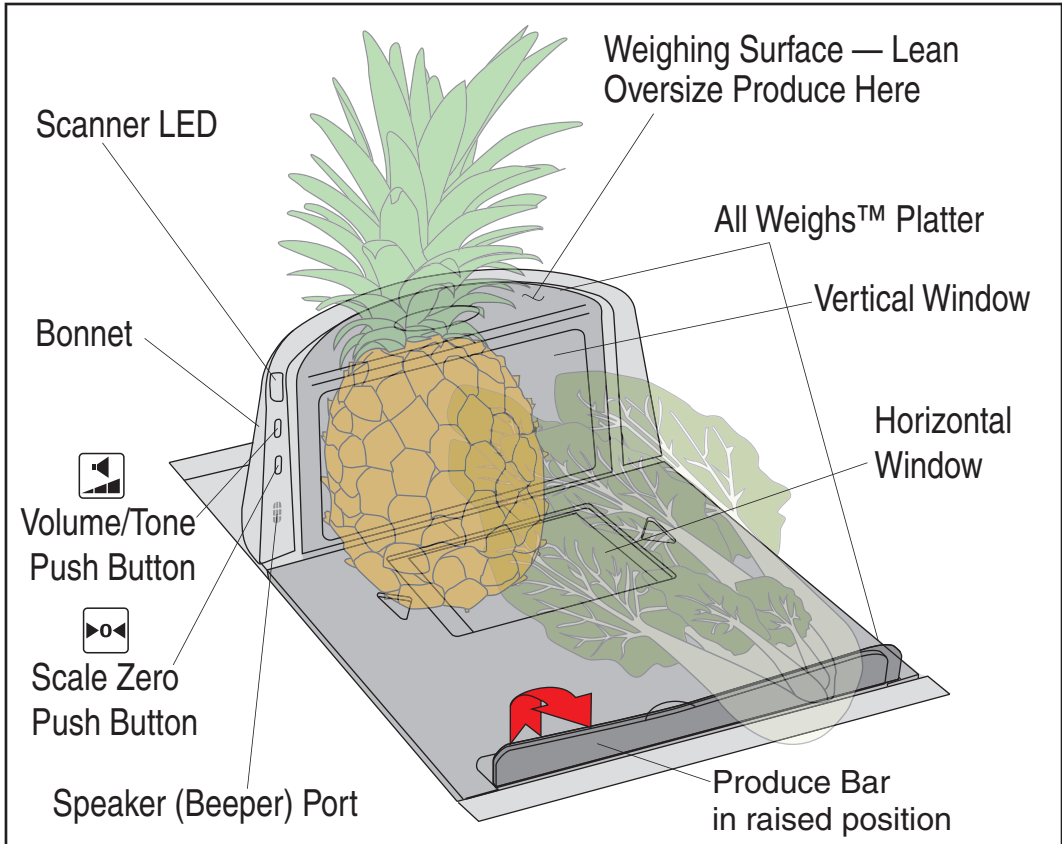



# Connections

Two connector panels are located on either side of the scanner as shown in **Figure 1-2**. The appearance of these panels will vary depending upon the factory options purchased with your model. Additionally, a service “pig-tail” extends from the scanner’s base to connect the control panel cable from the Bonnet area.

**Figure 1-2. Connectors**

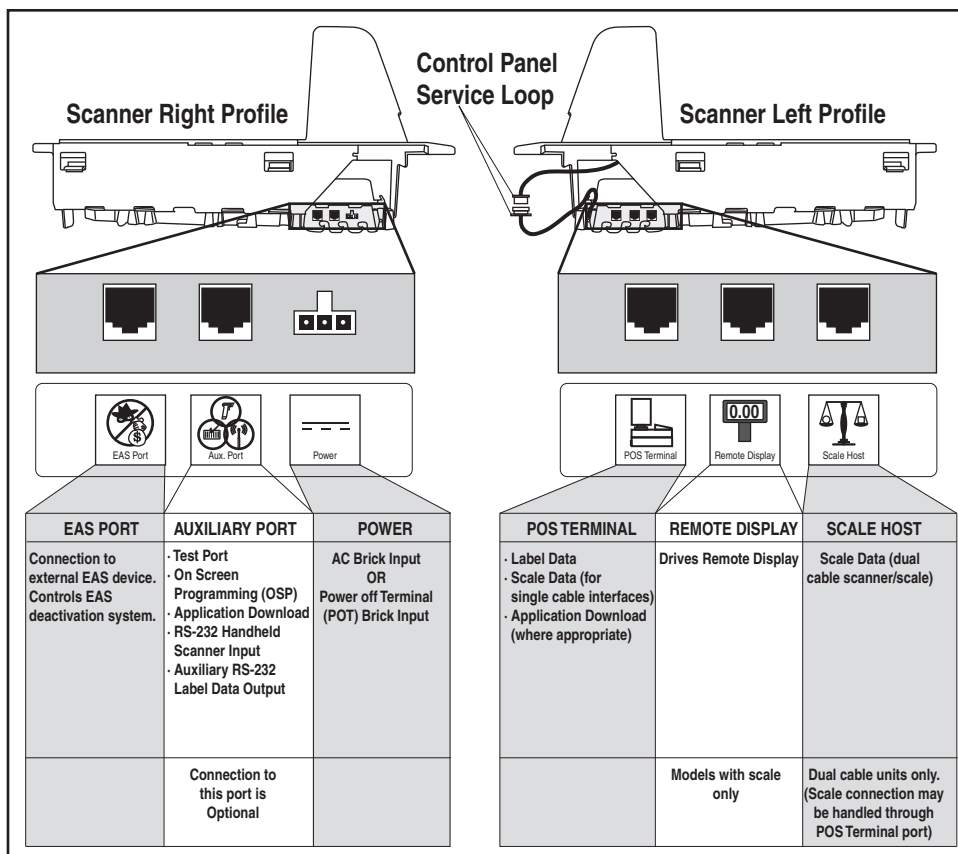

---

# Weighing

Specifications for scale capacity, settling time, minimum and maximum static weight, zeroing, and warm-up time are given below.

## **Rated Weight Capacity**

The scale's operational weight capacity is:

- 15.000 kilograms, displayed in 0.005 increments.

## **Minimum Increment**

The minimum weight that can be accurately measured by the scale is 0.005 kg.

## **Maximum Static Weight (Overload)**

A maximum static weight of 68 kg can be sustained by the scale without incurring damage or degrading performance.

---

## Warm-Up Time

There are two pertinent warm-up times that apply to the scanner or scanner/scale:



### NOTE

The two warm-up periods can be performed concurrently, thereby reducing the total required warm-up time to 60 minutes.

## Thermal Equilibrium

When the unit is moved from a cooler temperature (such as a storage area) to a warmer environment (such as a checkstand location), 60 minutes must be allowed to acclimate the unit to ambient conditions prior to calibration or operation.

## Power-up

Once installed and powered up, a warm-up time of 15 minutes must be allowed before calibrating or performing weighing operations.

## User Configurable Warm-up

The user may configure the unit for a pre-programmed warm-up time that is activated every time the scanner is powered up. During this time, the scale is viewed by the POS terminal as off-line.



### NOTE

Contact Technical Support to learn more about this advanced programmable feature.

**Figure 1-3. Environmental Specifications**

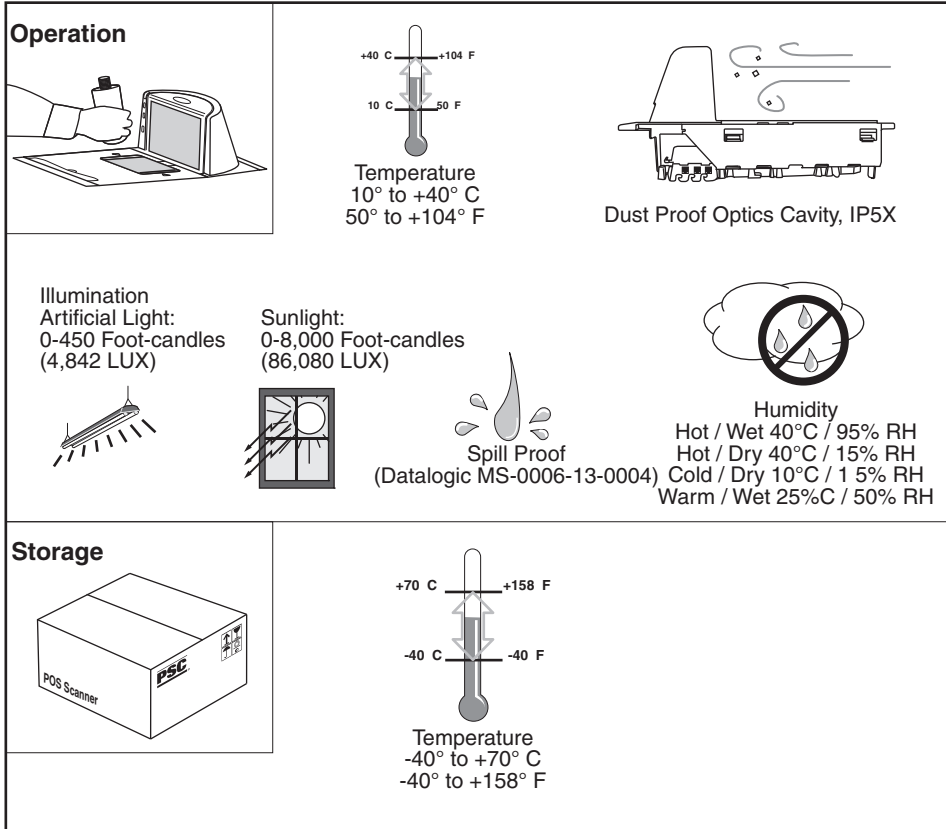

## Electrical Specifications

Before installation, always verify that the site’s electrical service meets the scanner/scale’s requirements. The scanner has been engineered for compatibility with most international electrical systems operating in ranges from 100 to 240VAC at 50-60 Hz. Verify that the power source will supply “clean” electrical power to the equipment; that is, it must be free of excess electrical noise.

## Power Supply

### Power Off the Terminal (P.O.T)

Certain units can receive power directly from the terminal (P.O.T.). A USB adapter “brick” connects the scanner to IBM-USB 12V ports.



#### NOTE

**Power supplied from the terminal does not include auxiliary power for alternative scales.**

### AC Adapter

Units which do not receive power directly from the terminal will use either a Listed Class 2 or Listed LPS power source which supplies power directly to the unit. When using such an AC Adapter, make sure to connect using the correct IEC power cord for unique and international power connections. If the cord will not plug into your AC power receptacle, the power cord shipped is not compatible with your electrical system. Please contact your distributor immediately to receive the necessary information and components to ensure electrical compatibility.

VOLTAGE	FREQUENCY
100-240VAC $\pm$ 10%	50-60 Hz



#### CAUTION

**Safe operation of your scanner or scanner/scale requires properly grounded electrical outlets. Be sure to have a qualified electrician certify the earth-ground connection on circuits which will be used to power the unit.**



#### NOTE

**The scanner is powered on/off by connecting/disconnecting it from its power supply.**

# Agency Compliances

The scanner and scanner/scale meets or exceeds the requirements for its device type as set forth by the following agencies and regulations:

COUNTRY	COMPLIANCE	COMMENTS
<b>Electrical</b>		
United States	UL 60950	
State of California	Energy Efficiency Standard	
Canada	CAN/CSA 60950	
Europe	TÜV EN 60950	
Mexico	NOM	
Korea	K-Mark	
Argentina	IRAM	
Taiwan	BSMI	
China	CCC	
Japan	PSE	
Australia/New Zealand	AS/NZ 60950	
<b>Emissions</b>		
United States	47CFR Part 15J	FCC Class B
Canada	ICES-0003	Class B
Europe	EN 55022	Class B
Australia/New Zealand	AS/NZS CISPR22	Class B
Japan	VCCI	Class B
Taiwan	CNS 13438 BSMI	
Korea	Mic Mark	

COUNTRY	COMPLIANCE	COMMENTS
ROW	CISPR 22	Class B
<b>Laser Safety</b>		
United States	CDRH, 21CFR Part 1040	CDRH Class IIa laser device
Europe	IEC60825-1:2007 EN60825-1:2007	Class 1 Class 1
<b>Weights &amp; Measures</b>		
United States	NIST Handbook 44	(Dept. of Commerce)
Canada	Measurement Canada	
Australia/New Zealand	National Measurement Institute	
Brazil	INMETRO	
EC Countries	Type Approval Cert	
Mexico	NOM	
Puerto Rico	Same as USA	
Singapore	Spring Singapore	
ROW	OIML R76	
Russia		

Contact Datalogic<sup>®</sup> Product Marketing at (541) 683-5700, or your Datalogic representative for a complete listing of approvals for other countries.

---

# NOTES



# Chapter 2

## Site Preparation and Installation

---

### Models

Scanner and scanner/scale models (reference [Figure 2-1](#)) are available in different lengths, allowing them to fit with little or no modification into openings cut for previously installed scanners such as Datalogic® Magellan® scanners, or NCR® scanner models 7820/24 and 7870. Other models are designed for applications with smaller footprint requirements.

[Figure 2-1](#) provides simplified illustrations of short, medium and long models. The appearance of your unit may vary. Scanner/scale models also offer an option for a raised Produce Rail, or a flip-up Produce Bar as shown in [Figure 2-3](#).

**Figure 2-1. Model Examples**

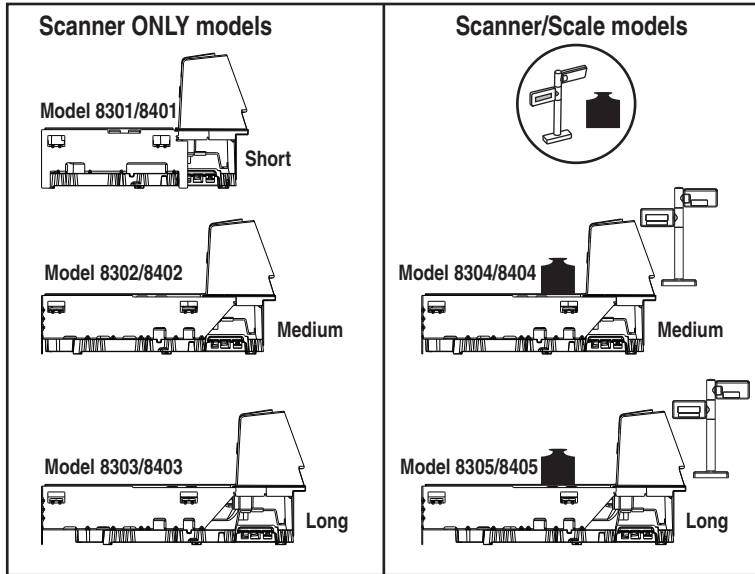

**Figure 2-2. Flanged and Shelf Model Examples**

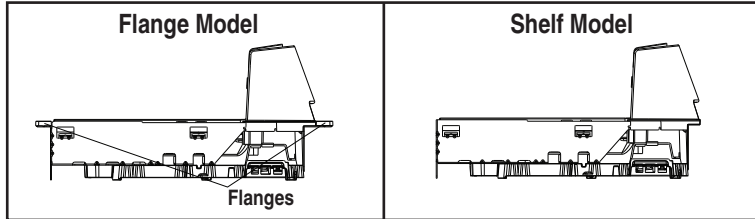

**Figure 2-3. Produce Bar and Produce Rail**

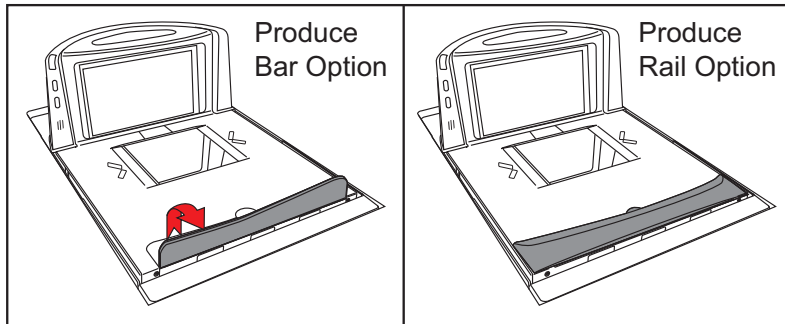

## Pre-Installation Considerations

It should be noted that the scope of this manual does not encompass all factors related to worker safety and checkstand design. It does, however, offer a list of considerations that may be helpful in ensuring greater safety and productivity. Careful planning using these general guidelines should result in a more efficient, comfortable work environment.

The U.S. Bureau of Labor Statistics reports that the incidence of repetitive motion injuries has increased dramatically in recent years. Checkstand design and scanner installation and operation procedures can reduce the risk of repetitive motion injuries, but not eliminate it.

Although there are currently no formal guidelines for checkstand ergonomics, the Food Marketing Institute (FMI) and the National Institute of Occupational Safety (NIOSH) of the Department of Health and Human Services have released the reports listed at the end of these recommendations. These reports contain useful suggestions for ergonomic improvement of checkstand designs and scanner installation, maintenance and usage. Portions of the reports are summarized below. For copies of the complete reports, or to inquire about any modifications to the recommendations, contact FMI and NIOSH at the addresses listed at the end of these recommendations.

## Checkstand Design

1. Select a design which allows load-sharing by several muscle groups (for example designs which allow the cashier to use both hands for scanning and bagging).
2. Select checkstands which deliver products to the cashier on an input belt and do not require the unloading of items from a cart. These designs put less stress on the cashiers' shoulders and back.
3. Minimize the distance between the input and take-away conveyors (i.e., the distance the cashier has to reach to move the products).
4. Minimize the width of the input conveyor to reduce the cashier's reach to items on the far side of the belt; use a diverter to direct products closer to the cashier.

- 
5. Select a design which encourages the cashier to slide products across the scanner rather than gripping and lifting. Make sure the horizontal surface of the scanner is flush with all surrounding surfaces.
  6. Choose a design which integrates the scanner and scale to eliminate extended reaches and lifts during weighing tasks.
  7. Provide an easily accessible bag stand at a height 13 - 17 inches (33 - 43.2 cm) lower than the top surface of the checkstand to reduce stresses to the shoulders, elbows, and risks associated with lifting products into bags.
  8. Do not position the bag stand between the cashier and the scanner, due to the increased reach involved.
  9. Position the scanner's horizontal scanning surface 34 - 36 inches (86.4 - 91.4 cm) above the floor. Maintain a minimum of five inches (12.7 cm) clearance between elbows and work surfaces.
  10. Provide adjustable keyboard mounting (height, tilt, and horizontal reach).
  11. Position the printer, cash drawer, and other checkstand devices the cashier uses within easy reach (less than 18 inches/45.7 cm).
  12. Provide adequate toe space, foot rests or rails, antifatigue mats, and where feasible, an adjustable seat or stand against which the cashiers can lean.

## Scanner Installation

1. Mount the horizontal surface of the scanner flush with the counter-top to encourage slide scanning rather than lifting.
2. Position the centerline of the scanner read area 8 - 10 inches (20.3 - 25.4 cm) from the edge of the checkstand (cashier side).

## Scanner Maintenance

1. Keep scanner windows clean. This will improve productivity and reduce rescans.
2. Replace scanner glass when excessive scratches are evident.

---

## Scanner Usage

1. Minimize handling of heavy/bulky products. Leave these items in the cart and use an alternative entry method such as key entry of short PLUs, or handheld scanning.
2. Regularly train cashiers in proper scanning methods and ergonomics principles, such as:
  - Develop a smooth fluid motion during scanning, sharing work equally between hands.
  - Use the entire hand for grasping and lifting items.
  - Since the scanner reads labels on all four sides plus the top and bottom, there is no need to turn a bar code toward either of the scanner windows.
  - Develop efficient scanning motions, not necessarily faster hand movements. Simply slide the item across the scanner's horizontal window with as little orientation motion as necessary.
  - Leave items in an upright position; do not lift and tilt.
  - Learn how the scanner functions and where the scanning area is located.
  - Do not favor either the vertical or horizontal window; slide items across the scanner in their natural orientations on the checkstand as much as possible.

## Site Preparation Overview

Consider the following factors before installing the scanner or scanner/scale and its optional Remote Scale Display.

**Ventilation Requirements** — The scanner operates without the use of a ventilation fan. As long as there is adequate convective air flow and no major heat producing equipment in close proximity, the unit's housing provides adequate heat dissipation. The air temperature in the checkstand around the scanner must not exceed 104°F (40°C).

---

**Service Access Requirements** — Routine operations such as ‘zeroing’ and calibration do not require removal of the scanner from the checkstand or disassembly of the product. The installer should plan service access for the AC/DC Power Supply and cables.

**Recommended Power Installation** — Since the typical grocery environment includes conveyor belts and electric motors, care should be taken to ensure that the scanner has a supply of “clean” power (power without excessive electrical noise). A wiring diagram shows the recommended wiring that will provide the scanner with a “clean” source of power. Refer to [Figure 2-6](#).

**Counter Preparation** — Since the majority of grocery checkout lanes are designed as “left-hand take away,” the counter drawings in this chapter focus on this counter design. Simply reverse the layout for a “right-hand take away” requirement. The unit scans equally well in either of these two configurations.

**Liquid Drainage** — Should a liquid spill occur, ensure that moisture can flow through the checkstand without pooling.

**Leveling** — Plan ahead and provide screws/bolts in the checkstand mounts and a leveling guide (board) to allow leveling of the scanner or scanner/scale within the counter. Use a 0.375” thick board to replicate the mounting flange on the long scanner or scanner/scale, and adjust screws or bolts until the board is flush within the counter. Use a 4.0” wide board stood on its end to adjust leveling screws/bolts in rail support applications.

**Cable Routing** — Placement of the scanner/scale should be planned to allow easy access to other components as well as optimize communication between the scanner, the POS terminal, the optional Remote Scale Display and any EAS peripheral equipment. Do not route interface cables near any electrical motors or other sources of electromagnetic interference.

**Remote Scale Display Placement** — The customer, and checker in some instances, must be able to easily view and read the Remote Scale Display. Ambient light and mounting height considerations are discussed later in this chapter.

**Vertical Clearance** — Provision must be made to allow adequate space above the scanner bonnet for removal and replacement of an L-shaped platter. Optimal clearance permits the platter to be grasped at its top vertical edge and lifted for removal without obstruction (such as a fixed keyboard mount or any type of enclosure). Should such an enclosure be unavoidable, an alternate method of platter removal using two coins may be employed, however a minimum vertical clearance of 1.5" (3.8 cm) MUST be provided (reference [Figure 2-4](#)). Another consideration is that the scan zone must be kept free of obstructions such as enclosures, keyboard mounts, etc.

**Figure 2-4. Vertical Clearance**

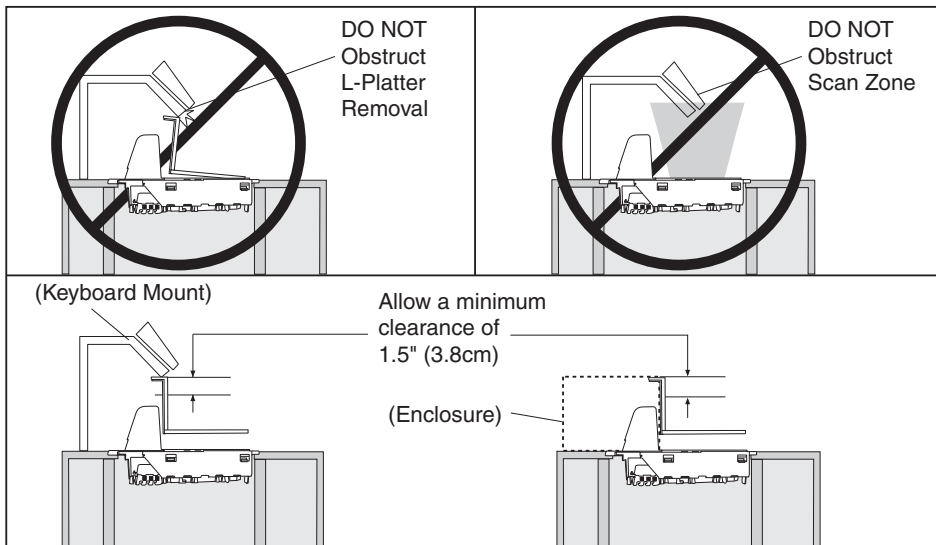

## Ventilation and Spacing

The scanner/scale's perimeter housing has been designed to provide adequate space for convective cooling and unrestricted movement of the weighing apparatus. [Figure 2-5](#) shows the debris chutes and ventilation slots. The checkstand design must allow:

- The ambient air temperature inside the checkstand adjacent to the scanner must not exceed 104°F (40°C).

- A source of air that provides adequate cooling by convective air flow.



**DO NOT** place the scanner in a close-fitting, fully enclosed checkstand. Provide a **MINIMUM** of 16 square inches (103.2 square centimeters) of air intake from below the installation for sufficient convective cooling.

**NOTE**

If motors, conveyor belts, or other heat producing equipment are located near the scanner, forced air ventilation may be required. In most installations, a 30 cfm (.84 cmm) axial fan should provide sufficient air movement. If a ventilation fan is installed, one with a removable filter that may be washed or replaced is recommended.

**Figure 2-5. Debris Chutes & Ventilation Slots**

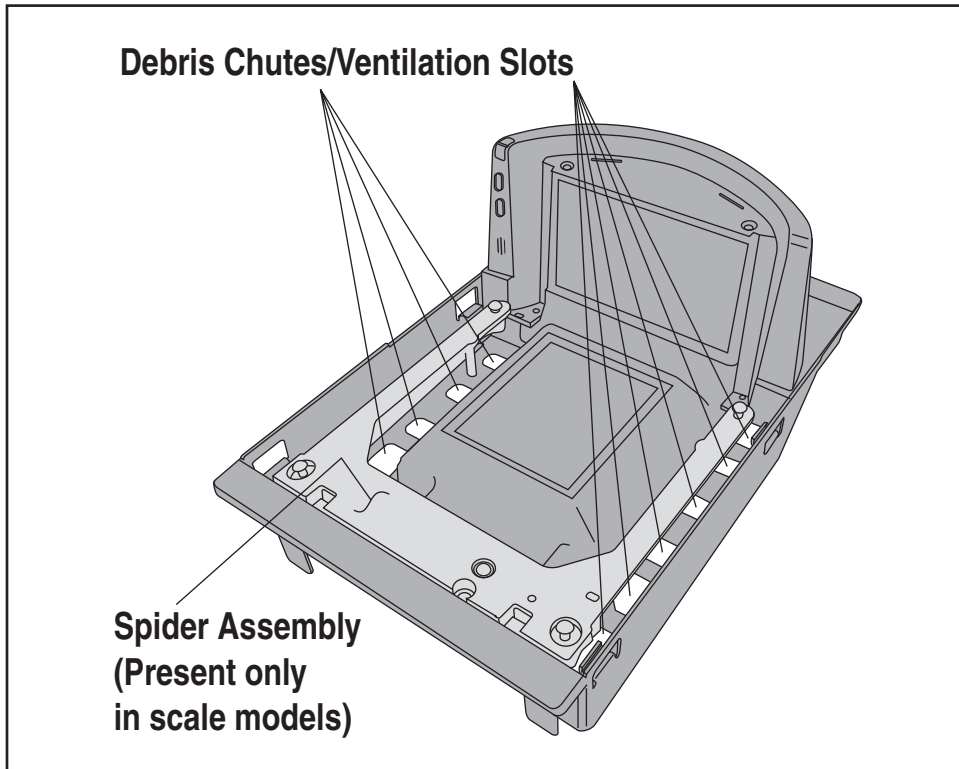



# Power Installation

Reference the wiring diagram in [Figure 2-6](#) for the recommended fusing arrangement.

## Grounding

The AC/DC Power Supply should have an AC outlet with a clean earth ground. If you are not sure how to verify the amount of electrical noise (interference) on the power line, ask a qualified electrician to measure the input line voltage.

**Figure 2-6. Input Power Wiring**

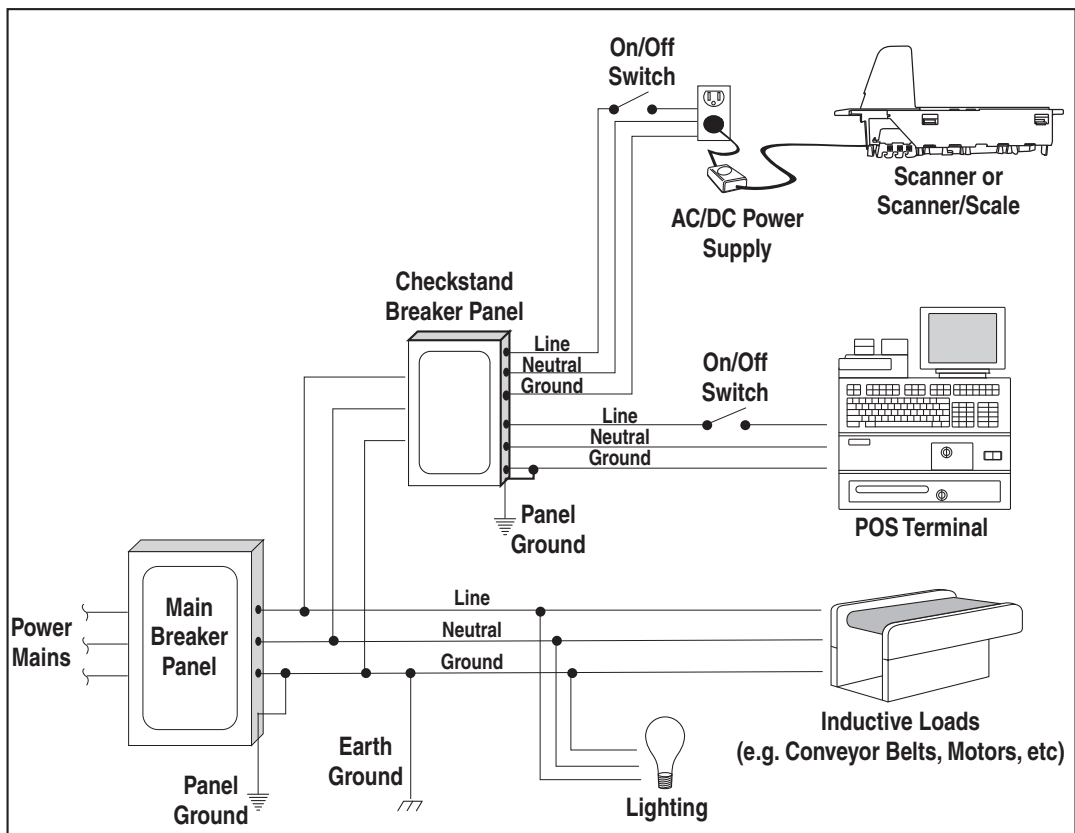

---

## Liquid Spills and Moisture

Select a checkstand design which allows fluids to flow through, and directs liquids away from any electronic equipment or storage areas.

## Counter Cutout

The most important consideration when planning the counter opening for the scanner is the operator's comfortable reaching distance. The ideal, ergonomically sound installation allows items to be directed within easy reach, and a scanning area requiring no lifting or special orientation of items. If you haven't already read the information at the beginning of this chapter titled, **Pre-Installation Considerations**, please do so before continuing these instructions.

The symmetrical design of the scanner permits the operator to easily pass items from one hand to the other while scanning (either from right-to-left or left-to-right). With the unique 360- scan zone, scanning is accomplished in one fluid motion. The operator simply slides the item from the conveyor belt or diverter area through the scanning area and passes the item to the other hand, which in turn bags it or places it on a take-away conveyor belt. Movement should flow naturally over the surface of the scanner.

Note that the following guidelines for preparing an existing checkstand to accept a scanner, or incorporating the unit into a new checkstand design will not be accurate for all installations. Although these guidelines will suffice for most standard installations, the installer may need to make adjustments for varying counter heights and thicknesses, support design, or other checkstand limitations.

**Figure 2-7** shows a typical “left-hand-take-away” checkstand design.

Follow these basic steps to install the unit:

1. Select a position for the scanner that offers a smooth product flow which best accommodates the reaching distance of the average operator.
2. Cut the opening in the countertop. Reference **Table 2-1** to find the cut-out dimensions for your model. Flange and shelf mount dimensions are provided for your convenience.

3. Install the AC/DC Power Supply, the Remote Scale Display cable (if Remote Display is used) and the interface cable(s) observing the following:

Interface cables (and display cable, if applicable) should be routed away from all highly inductive electrical devices, like motors and conveyor belts, and even away from the unit's power cable if possible.

Cables should be easy to remove in the event that replacement is required. A little planning now will save a lot of frustration later.

4. Connect and verify all system operations.

The scanner should be installed so that leading and trailing edges of the L-Platter are flush with the countertop to enhance smooth, slide-through scanning (reference the insert in [Figure 2-7](#)). Keep in mind that the debris chutes on both sides of the platter provide the necessary clearance for proper scale operation if you are installing a scanner/scale (you won't need to provide an additional gap for that).

**Table 2-1. Cut-Out Dimension References**

MODEL(s)	TYPE	FLANGE/SHELF OPTION	DIMENSIONAL REFERENCE
8302/8304 8402/8404	Medium Scanner/Scale	Shelf	<a href="#">Figure 2-8</a>
8302/8304 8402/8404	Medium Scanner/Scale	Flange	<a href="#">Figure 2-10</a>
8303/8305 8403/8405	Long Scanner/Scale	Shelf	<a href="#">Figure 2-12</a>
8303/8305 8403/8405	Long Scanner/Scale	Flange	<a href="#">Figure 2-14</a>

**Figure 2-7. Typical Checkstand Design & Cutout Location**

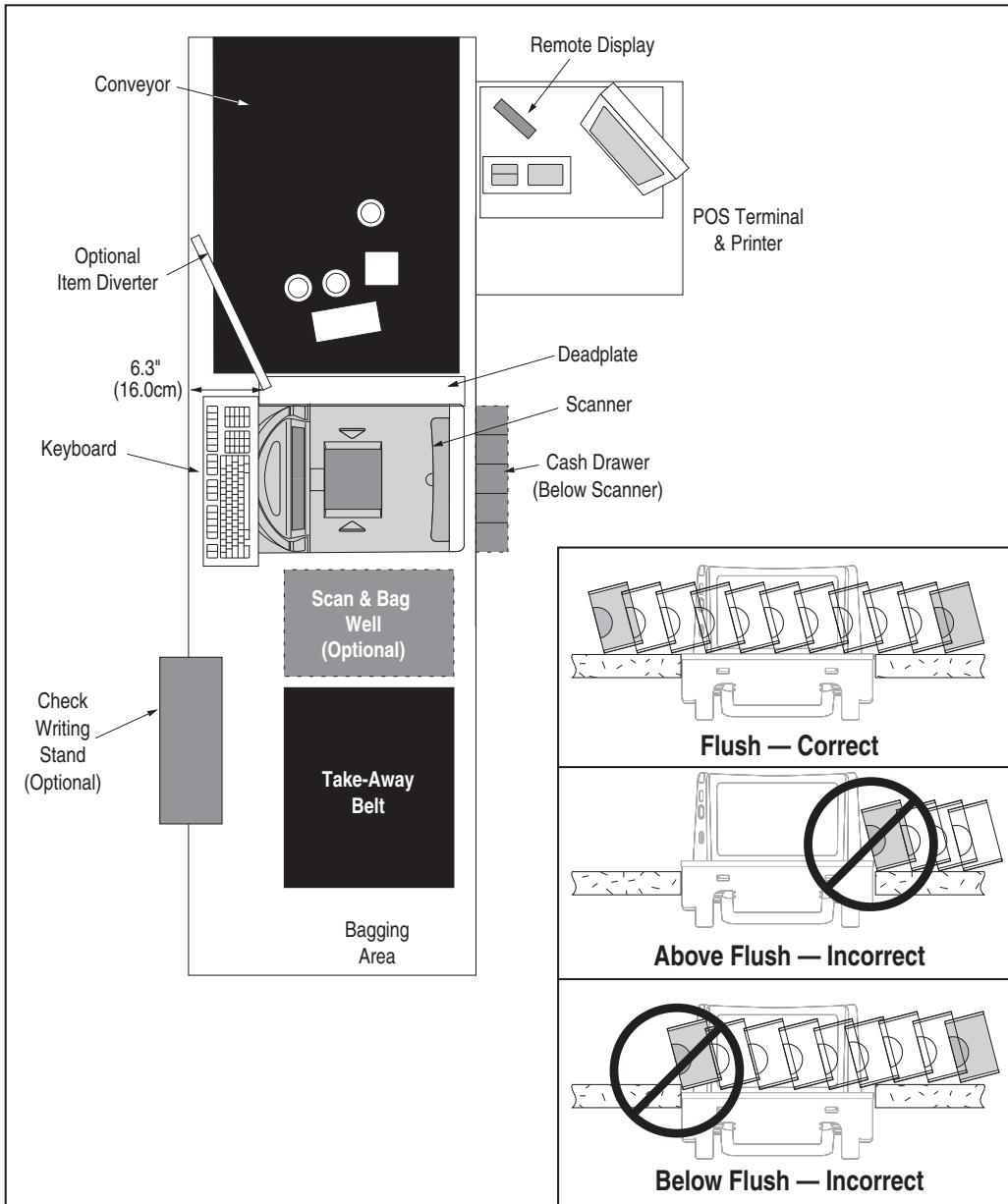

**Figure 2-8. Medium Shelf Models 8302/8304/8402/8404  
Cutout Dimensions**

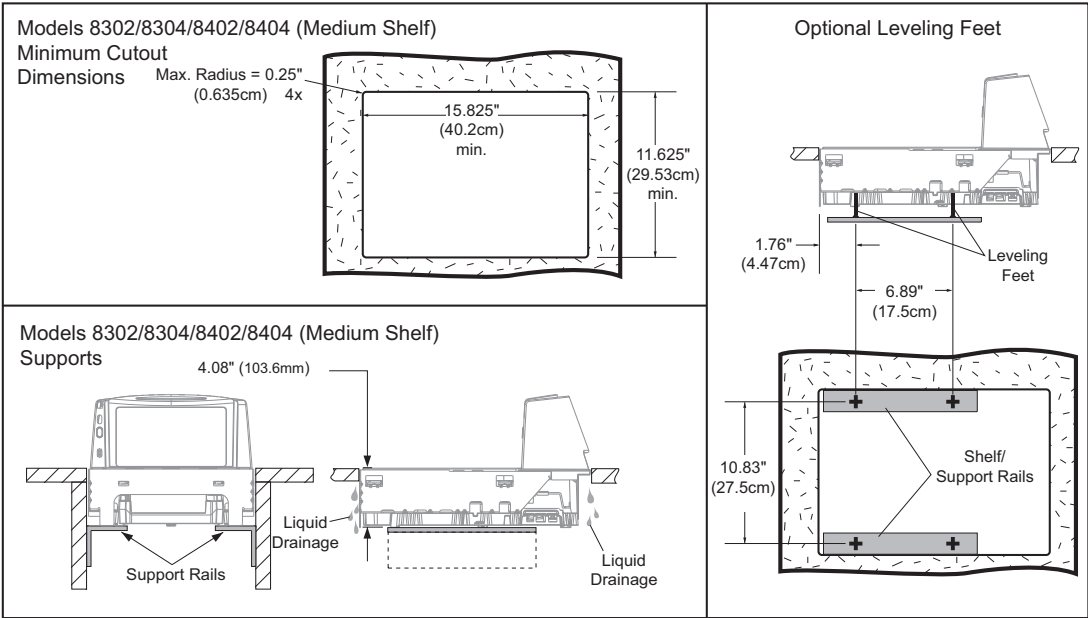

**Figure 2-9. Medium Shelf Models 8302/8304/8402/8404  
Scanner Reference Dimensions**

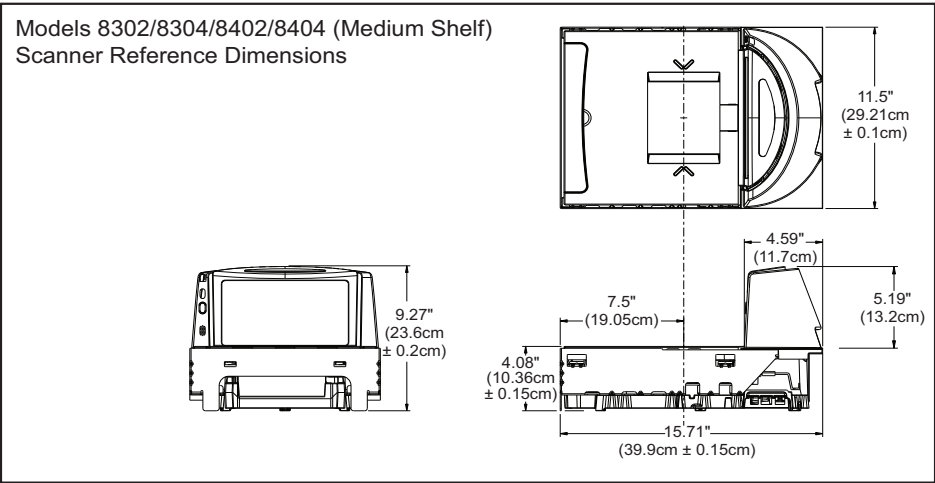

**Figure 2-10. Medium Flanged Models 8302/8304/8402/8404 Cutout Dimensions**

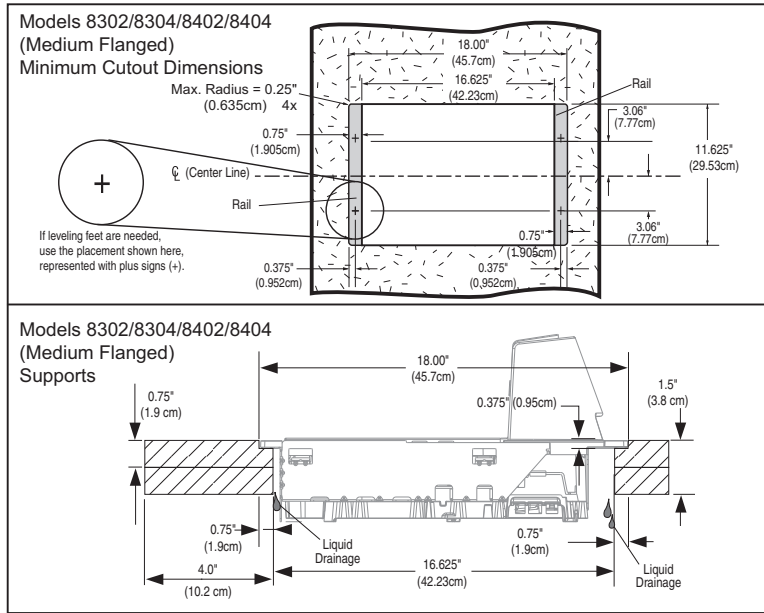

**Figure 2-11. Medium Flanged Models 8302/8304/8402/8404 Scanner Reference Dimensions**

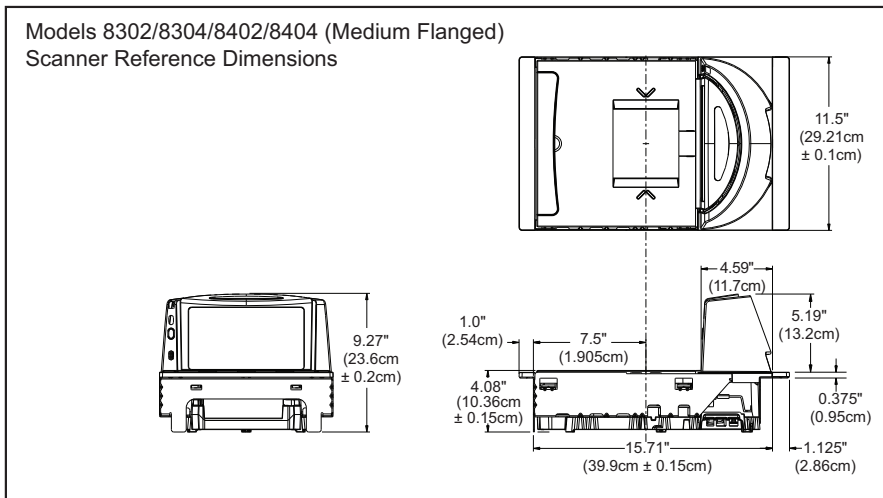

**Figure 2-12. Long Shelf Models 8303/8305/8403/8405  
Cutout Dimensions**

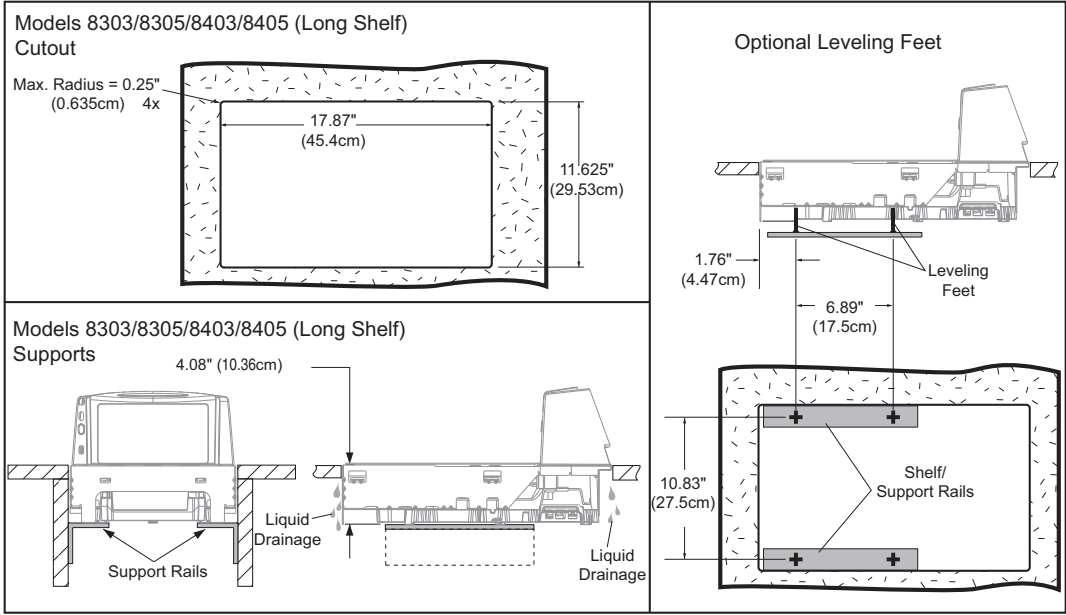

**Figure 2-13. Long Shelf Models 8303/8305/8403/8405  
Scanner Reference Dimensions**

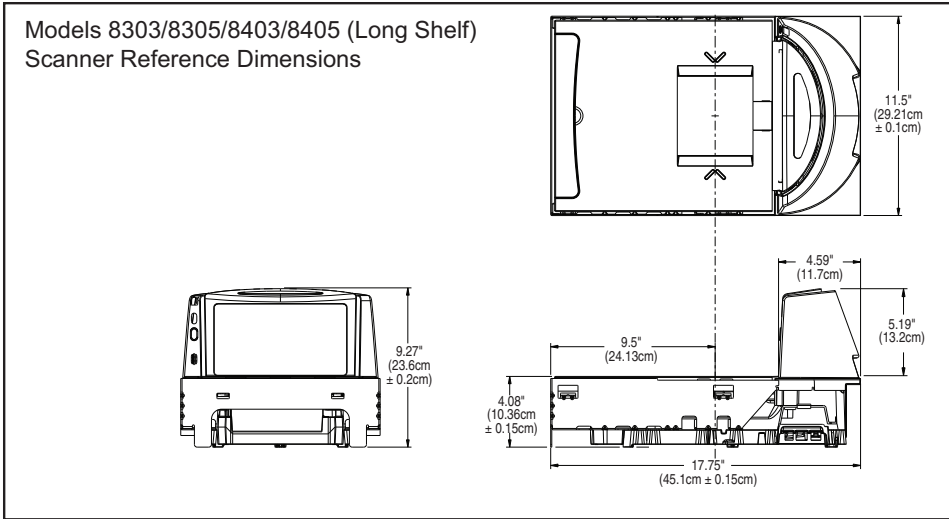

**Figure 2-14. Long Flanged Models 8303/8305/8403/8405  
Cutout Dimensions**

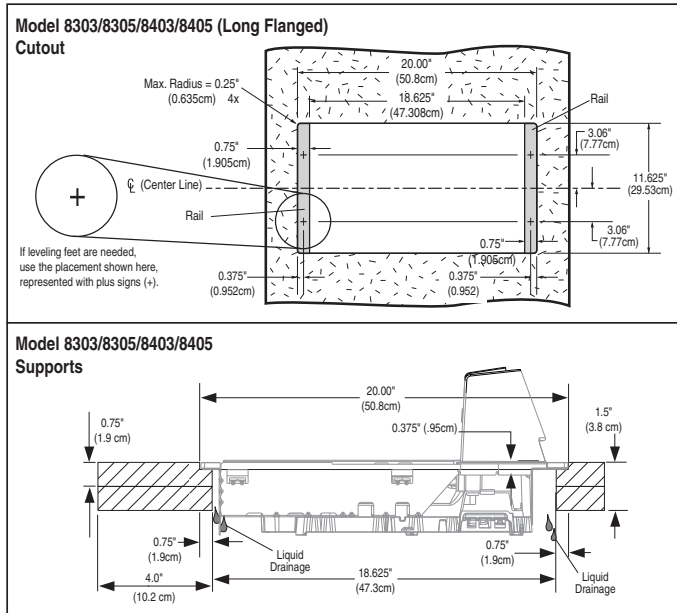

**Figure 2-15. Long Flanged Models 8303/8305/8403/8405  
Scanner Reference Dimensions**

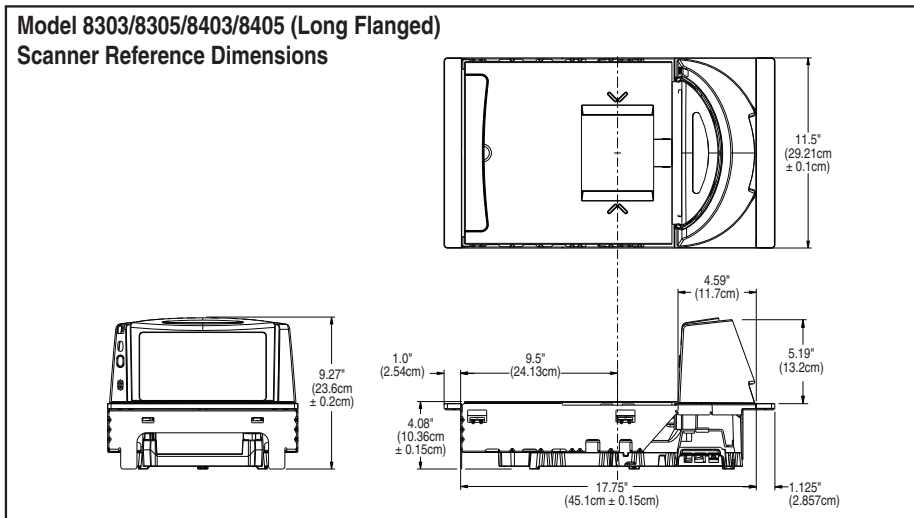



# Installation Overview

The preceding [Site Preparation Overview](#) dealt with installed location and counter preparations to accommodate the scanner or scanner/scale. Having completed those steps, physical installation of the scanner or scanner/scale can begin. The following instructions apply to all models.

This chapter describes:

1. Unpacking the unit.
2. Verifying operation before connecting to a POS system.
3. Routing and connecting cables.
4. Validating that your scanner communication parameters match the POS terminal's system requirements.
5. Confirming connection to the (optional) EAS system.
6. Functional testing to verify operation when connected to the POS system.

The following text describes each of these steps.

## Unpacking

To unpack the unit:

- Inspect the package for signs of damage that may have occurred during shipping. If damage is found, report it to your carrier immediately.
- Lift out the accessory box containing the AC/DC Power Supply, optional Remote Scale Display and cable (if present), and the Quick Reference Guide.
- Remove the Quick Reference Guide and familiarize yourself with the unit's controls and features. Leave the guide at the checkstand when the installation is complete.
- Remove the protective packing and carefully lift the unit from the carton. Be sure to save the box and all packing material. In the event of failure, the unit must be returned to the factory in its original packaging.

- 
- Carefully lift off the L-Platter as shown in [Figure 2-22](#) and remove the protective foam pieces securing the weigh mechanism. Set the platter back in place.



For added protection during shipment, the L-Platter is covered with a tight-fitting layer of vinyl. This vinyl layer **MUST BE REMOVED** before placing the unit into service.

**NOTE**

## Scale Diagnostic Mode

To enter Scale Diagnostic Mode, press the Scale Zero Push Button for approximately four seconds. Six rapid tones will be sounded, indicating the unit is leaving normal operation and entering Scale Diagnostic Mode. The Remote Display will flash a '1' across the display while the diagnostic routine is being run. When diagnostics are completed successfully, the display will indicate that the unit has passed the diagnostic test by displaying **PASS**. Next, the display shows a listing of how many times the unit has been calibrated and zeroed in the form of: **c XXX** where x equals the number of times the scale has been calibrated. Next, the unit will display **Zero XXXX** where x is the number of times the scale has been zeroed. Finally, all segments will be displayed in the form of: **-18.8.88** to allow visual verification of display function.

If the diagnostics routine is not completed successfully, the scanner will sound a series of tones and the Remote Display will show an error code. Turn to [Chapter 3, Problem Isolation](#), for a description of error codes.

Press the Scale Zero Push Button once more to reset the unit and exit Scale Diagnostic Mode.

## Cables & Connections

Considerations when routing the power and interface cables for the scanner and scanner/scale are:

- Ensure that cables are not pinched, kinked or pierced.
- Do not route interface cables in close proximity to electrical motors or other sources of electromagnetic interference.

Do not plug the AC power cord into the outlet at this time. It is a good practice to always connect the power cable to the scanner first before plugging it into the AC receptacle. The procedures titled, Set-Up, provided later in this chapter will instruct you to connect the power cord at that time.

---

Figure 2-16 provides physical dimensions for the AC/DC Adapter (part number 8-0582).

**Figure 2-16. Physical Measurements: AC/DC Adapter**

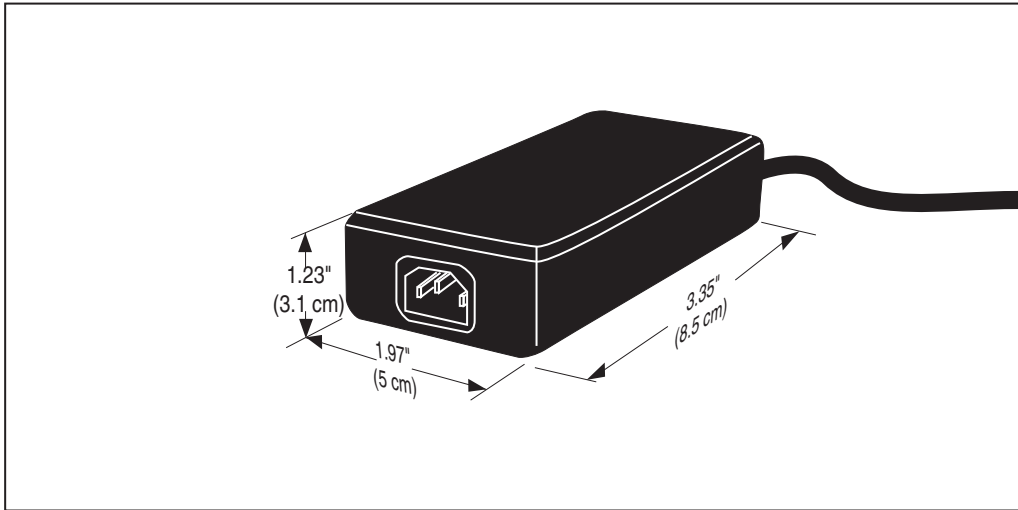

## Remote Scale Display Placement/Installation

The modular Remote Display is designed so that single display heads can be stacked to form a dual display as shown in Figure 2-17a in order to address the specific viewing needs of both the customer and the cashier. Factors to consider when installing this device are:

- Lighting Considerations
- Viewing Angle
- Remote Display Cabling

## Lighting Considerations

The display(s) will be easily readable unless placed in direct sunlight or other very strong light sources. Light interference will not be a factor in most installations. For best viewing, the display head(s) can each be rotated up to 180° around the post and/or tilted 15° backward or forward.

## Viewing Angle

The optimum display angle is directly facing the viewer. Tilt and rotation adjustments can be made as shown in **Figure 2-17b**. To ensure that displays are easily readable for customers/cashiers of average height, display heads should be between 48" to 60" (122 to 152 cm) from the floor.



**Check with local Weights and Measures authorities regarding proper positioning of scale displays used in retail trade.**

### NOTE

**Figure 2-17. Modular/Adjustable Remote Scale Display**

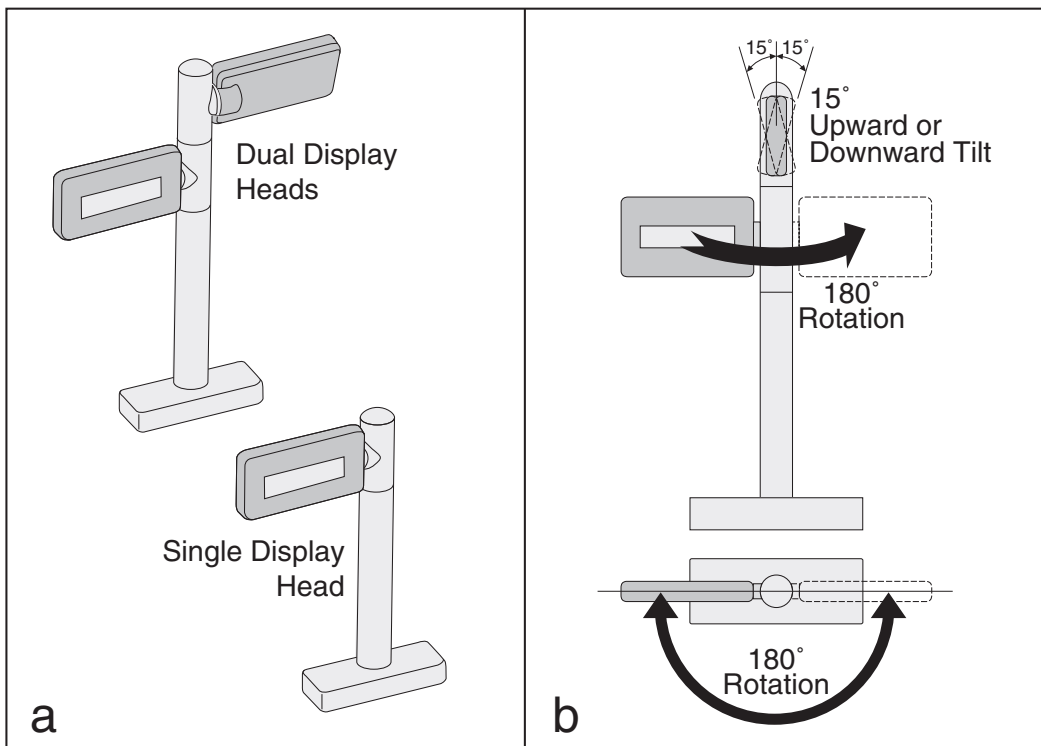

---

## Remote Display Cabling

Your installation should also take into account the routing of Remote Display cabling. Ensure that distance and obstacles spanned by the routed cable will not kink, pinch or stretch it. Also keep in mind you may need to drill a hole through which to route it.



### NOTE

The Remote Scale Display connector end may be secured with a rubber band during shipping to prevent damage to the “locking tabs” (see Figure 2-19). After routing the cable, remove this rubber band before connecting. Failure to remove the band will keep the connector from latching properly.

## Placing and Installing the Remote Scale Display

Reference [Figure 2-19](#) while performing these procedures.

1. Determine where you want to install the Remote Scale Display based on your counter design, the viewing angle, lighting considerations and cable routing discussed previously. Reference [Figure 2-17](#) for the display’s physical dimensions. Optimally, the display(s) should be approximately eye level to the viewer(s).
2. Use the template provided in [Figure 2-20](#) to mark locations of the mounting screw and cable routing holes. The mounting screw holes are on 3-1/2” (85.1 mm) centers. The cable can either be routed through a 3/4” (19 mm) diameter hole directly under the mounting base or through the cutout in the back of the base (see [Figure 2-19](#)).
3. Drill the mounting screw holes using a drill bit of the appropriate diameter for your mounting screws or bolts.
4. Drill the cable routing hole using a 3/4” (19 mm) drill bit (optional).

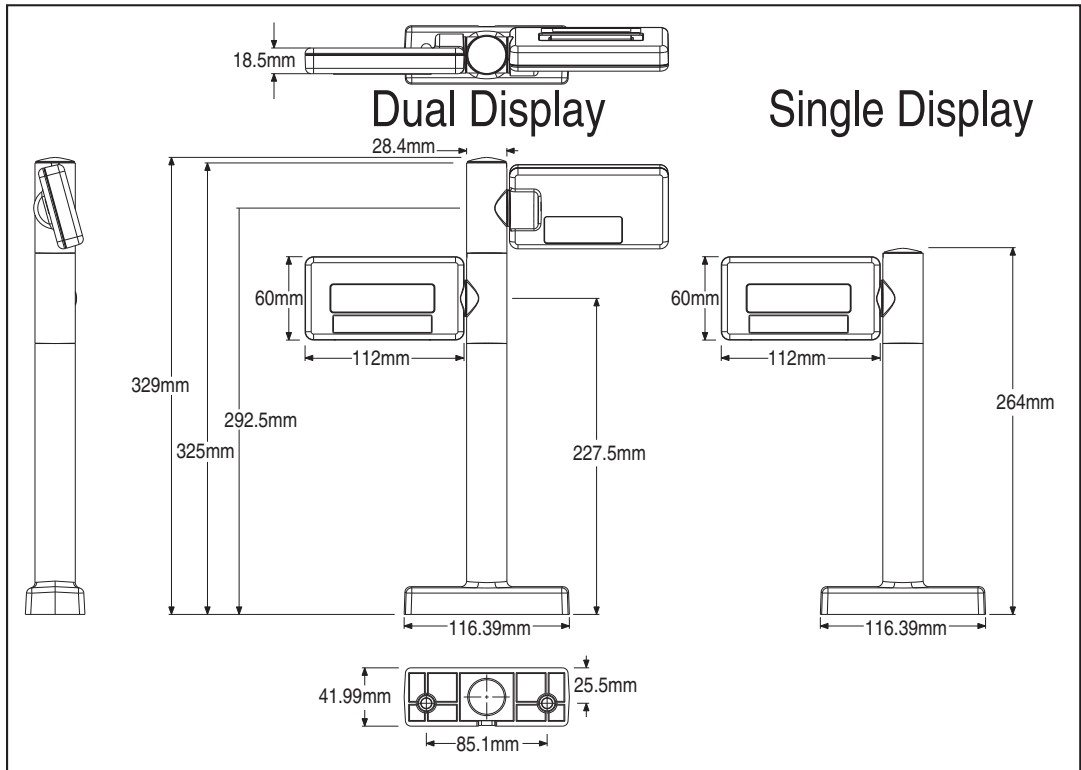
**Figure 2-18. Physical Measurements: Remote Display**

5. Feed the entire length of the Remote Scale Display interface cable through the cable routing hole so that the assembled Remote Scale Display can be positioned over the mounting screw holes.
6. If present, remove the rubber band from the connector end.
7. Install mounting screws or bolts to complete the installation of the Remote Scale Display. Take care not to pinch or pierce the interface cable while securing the Remote Scale Display to the checkstand.

**Figure 2-19. Remote Scale Display Mounting**

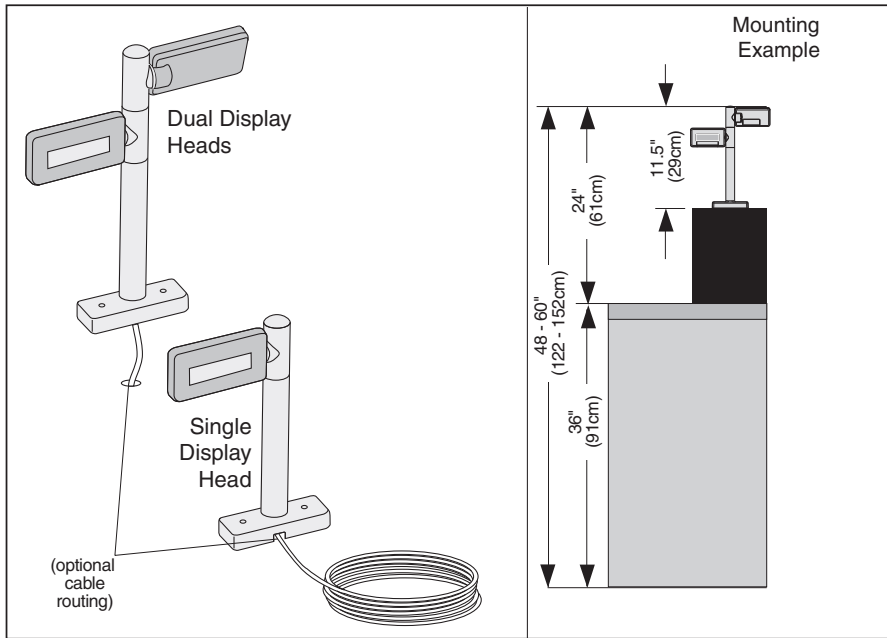

**Figure 2-20. Remote Scale Display Mounting Template**

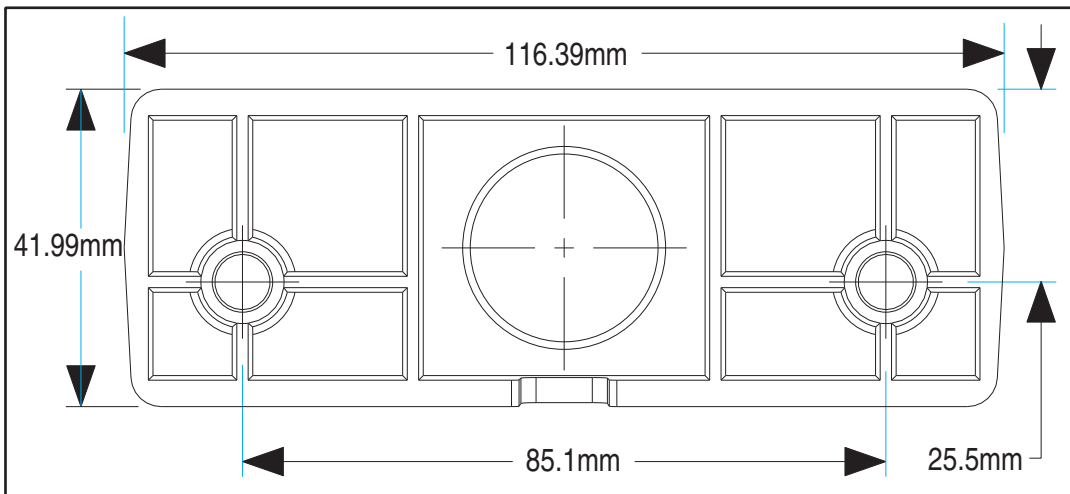



---

# Set-Up & Installation

These setup and installation procedures assume that you have already prepared your checkstand to receive the scanner or scanner/scale. If you have not already made the counter cutout and routed power and interface cables, do so now as described in the previous instructions. If your checkstand has been prepared, proceed as follows:

## Set-up

1. Place the scanner on the checkstand next to the counter cutout.
2. Make all connections to peripheral devices, such as the Remote Scale Display (see [Figure 2-19](#)) and, if your installation includes an EAS system, refer to that manufacturer's instructions for connection and start-up procedures.
3. Route the cables up through the cutout and connect the scanner and scale interface cable(s), EAS cable and Remote Scale Display cable (optional) to the scanner. Some POS terminals require two interface cables; one for the scanner interface and one for the scale interface. Refer to [Figure 2-21](#) for cable connection locations.

If you have a scanner with no scale, there will be only one interface cable to the POS terminal.

4. Connect the power cord to the scanner and route the other end down through the checkstand to the AC power outlet. **DO NOT** plug the power cord in at this time.

**Figure 2-21. Connecting Cables to the Scanner/Scale**

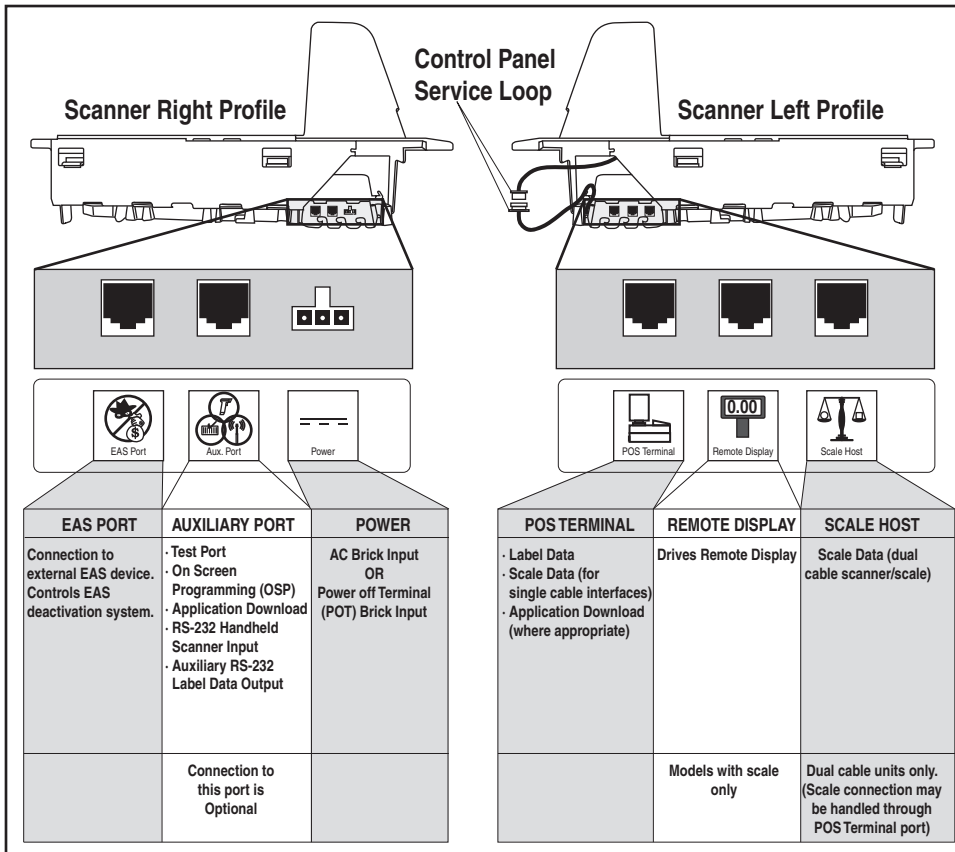

## Installation

1. Make sure that all cables are firmly attached (except that the AC/DC power supply should not be connected to the AC outlet yet). Reference [Figure 2-21](#).
2. Remove the platter to gain access to the interior lift handle. Grasp the platter in the positions shown in [Figure 2-22](#) and gently lift it from the scanner. If the top edge of the platter is blocked, you may find it easier to grasp the platter vertical bezel as shown in [Figure 2-22b](#).



### NOTE

Figure 2-22 illustrates an L-shaped weigh platter, which features a vertical bezel. Your platter may not contain a vertical bezel.

**Figure 2-22. Removing the Platter**

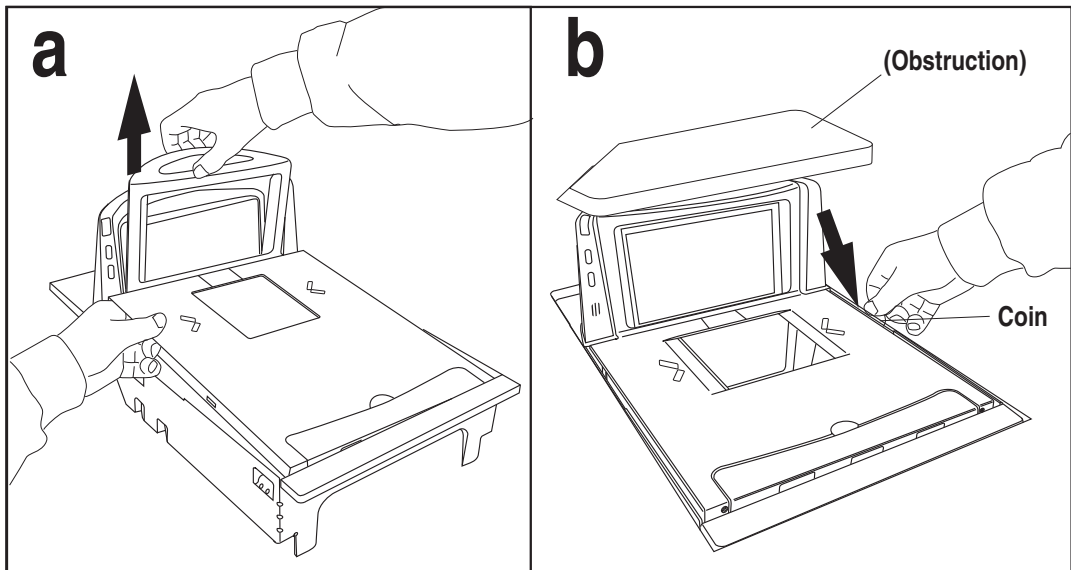

3. Rotate the Interior Lift Handle up as shown in **Figure 2-23** and hook the fingers of both hands in the lift handles indicated. **DO NOT** attempt to lift the unit using the plastic edges, scale frame, or any features other than the lift handles.
4. Lower the unit into the counter opening, ensuring that none of the cables are pinched, pierced or crimped.
5. Re-install the Platter and verify that it is flush or just below flush with the countertop. This is necessary to provide smooth scanning from either direction. Make adjustments as needed to align the platter with the counter by moving support rails up or down, or consider installing screws in positions that will allow their use in adjusting the unit's position.



**NOTE**

Failure to install a scanner/scale in a stable and level position will inhibit weighing, calibration and zeroing operations. The platter **MUST** make unobstructed contact with all of its supports for proper weighing operation.

6. Once installation is complete, proceed with the **Scale Diagnostic Mode** procedures that follow.

**Figure 2-23. Using the Lift Handles**

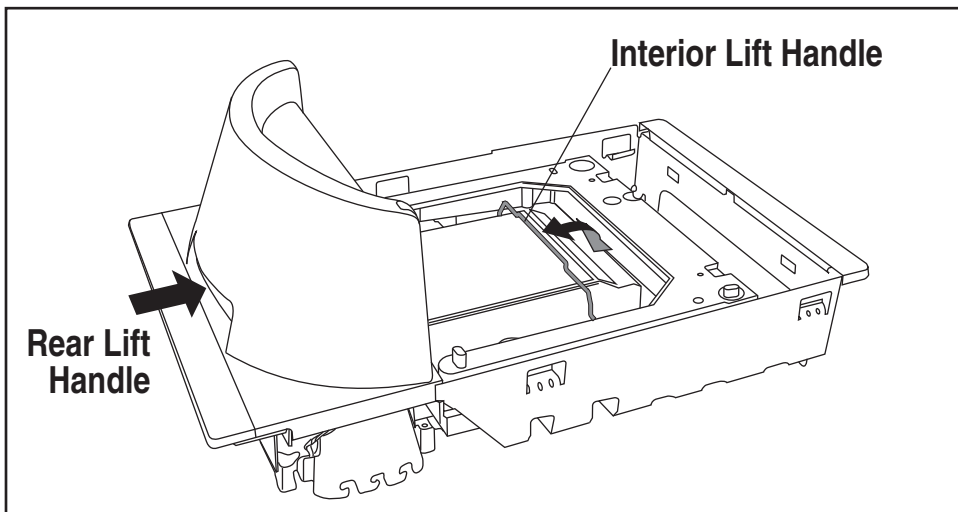

# Chapter 3

## Problem Isolation

---

In the event of a suspected functional problem, use the troubleshooting references provided in this chapter. This useful information will help you to identify and resolve the cause of the problem.

The scanner/scale has a number of features that indicate when a scanner or scale problem occurs. The unit may:

- emit a series of tones
- light the 7-segment (FRU status) display
- flash one or more LEDs
- display error codes on the Remote Display (if installed)

Three error reporting modes are used: Power-Up Selftest, Operational tests and Diagnostic tests. These test sequences are explained on the following pages.

### **Power-Up Selftest**

The Power-up Selftest is a pre-operational series of tests that must be successfully completed before the scanner indicates readiness for operation. This pre-operational period is the time between power-up and normal operation during which the motor comes up-to-speed and software, firmware and hardware are being tested. These tests ensure that all subsystems are fully functional before turning on the Visible Laser Diode (VLD).

---

## Operational Tests

These are the tests that run continually during Normal Operation and Sleep Mode. Firmware checks all subsystems, accessory connections and the POS interface to verify everything is operating normally. If a problem is detected at any time, a long, low tone is sounded, an error code is shown on the 7-segment display, and operation may be halted. If you press the Volume/Tone Push Button at that time, a series of tones will be sounded that matches the error code displayed.

## Diagnostic Tests

See [Chapter 2, Scale Diagnostic Mode](#), for details about running diagnostic tests for the scale. If a problem is discovered during diagnostics, the scanner will provide feedback about the source of the problem. The remainder of this chapter describes these failure indications and includes troubleshooting flowcharts to help isolate the problem.

## Diagnostic Procedures

Your Point-Of-Sale (POS) system may contain many components that operate as a system. Since almost all scanner or scale problems are caused by either the scanner, scale, POS terminal or communication links between them, these troubleshooting flowcharts focus on these components. Additionally, the optional Remote Scale Display, AC/DC Power Supply and their cables are potential problems addressed in this chapter.

The flowcharts provided in this chapter walk you through a diagnostic process that will isolate the failed component and instruct as to the corrective action required. Since internal scanner and scale components cannot be replaced by an operator or installer, most functional errors will require the assistance of a trained technical support person. However, if the problem is caused by faulty cable, power supply or remote display, you can fix the problem by replacing the defective component and complete the installation.

## Error Codes

If an error is detected, the scanner will sound a long low tone (for one second) and alternately flash its LEDs, indicating a failure. Following the long low tone, an error code will appear on the 7-segment display (refer to [Figure 3-1](#)). Pressing the Volume/Tone Push button will cause the scanner to sound a series of beeps corresponding to that error code. [Table 3-1](#) on the following page describes what these codes mean and what action should be taken for each.



### NOTE

**When troubleshooting, always remember to check all cable connections first before proceeding with other problem isolation steps.**

---

**Table 3-1. Error Codes**

<b>Error Code</b>	<b>Probable Cause</b>	<b>Corrective Action</b>
0 Blinking	Configuration	No POS interface has been selected (Null interface). See <a href="#">Chapter 5, Interface Type</a> to select the required interface using programming bar codes.
1	Configuration Error	See <a href="#">Chapter 5, Programming</a> , for details about configuring the scanner using programming bar codes.
2	Interface Board	Unplug unit and call technical support personnel.
3	Motor	Unplug unit and call technical support personnel.
4	Horizontal Laser <sup>a</sup>	Call technical support personnel.
5	Vertical Laser <sup>a</sup>	Call technical support personnel.
6	Digital Board	Unplug unit and call technical support personnel.
7	Scale	See the topic <a href="#">Scale Error Reporting</a> in this chapter for problem identification and corrective actions.
8	Remote Display	Connect the Remote Display. If necessary, replace display or cable. Alternatively, you can disable the Remote Display using the programming procedures described in <a href="#">Chapter 5</a> .
A	Control Button Stuck	Check to see if either of the buttons is stuck; free it if possible. If neither button is stuck, call technical support personnel.
B	Hardware ID	Call technical support personnel.
C	Scale Calibration	Calibrate scale or call technical support personnel.
E	CPLD ID	Call technical support personnel.
Decimal Point	3.3 V Present	If not lit, call technical support personnel

- a. If only one laser is non-functional, the scanner may continue to work (this is a configurable feature); however, the 7-segment display will show the error code indicating the failed laser. If both lasers have failed, the 7-segment display will display either a 4 or a 5, and the scanner will cease to function until serviced. No alternate blinking of lamps will occur if only one laser has failed.

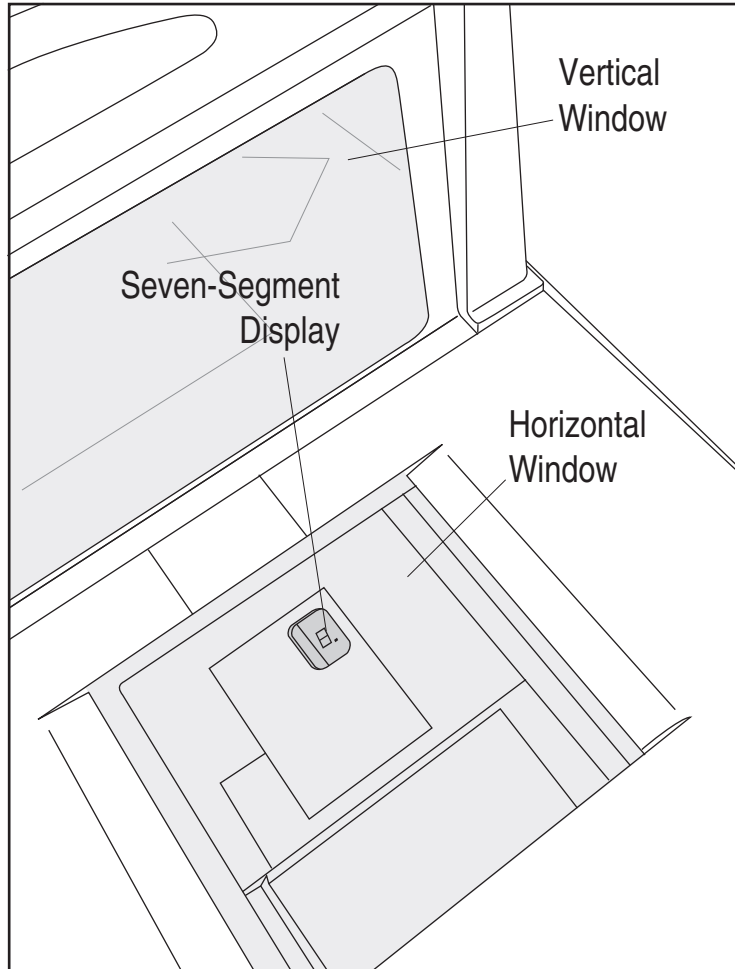

**Figure 3-1. 7-Segment LED Display**

---

# Scale Error Reporting

Scale diagnostics uses the Remote Scale Display and the Zero Status lamp to communicate specific scale failures. The following chart shows the Remote Display messages, the Scale Status lamp indication, the problem that the scale is experiencing and what action should be taken. When troubleshooting, always remember to check all cable connections first before proceeding with other problem isolation steps.

Remote Display	Scale Status Lamp	Problem Description	Action Required
E__1	Flash, pause, 1 blink, long pause, repeat sequence.	Too much motion at power-up.	Check for stable installation. Change scale motion filter using the labels found in <a href="#">Chapter 5</a> ; restart. If problem persists, scale may require calibration.
E__2	Flash, pause, 2 blinks, long pause, repeat sequence.	Calibration lost.	Call technical support personnel. Recalibrate; restart; recertify (if required).
E__3	Flash, pause, 3 blinks, long pause, repeat sequence.	Scale communication lost. Internal scanner/scale problem.	Call technical support personnel; report error.
E__4	Flash, pause, 4 blinks, long pause, repeat sequence.	Scale module failure.	Call technical support personnel; report error.
E__5	Flash, pause, 5 blinks, long pause, repeat sequence.	Internal software fault.	Call technical support personnel; report error.

Other Scale Reporting

---

Remote Display	Scale Status Lamp	Problem Description	Action Required
- 0 -	Off	Cannot zero at power-up or weight remains on scale for more than 2 minutes or weight has not returned to zero between POS weight requests <sup>a</sup> .	<ul style="list-style-type: none"><li>- Check debris chutes.</li><li>- Verify that the weigh platter moves freely.</li><li>- Remove item(s) from scale</li><li>- Press Scale Zero Push Button</li> <li>- for more information.</li> <li>- If the scale still fails to zero, recalibrate the scale.</li></ul>

a. This is a configurable feature.

**Figure 3-2. Problem Isolation: Remote Display**

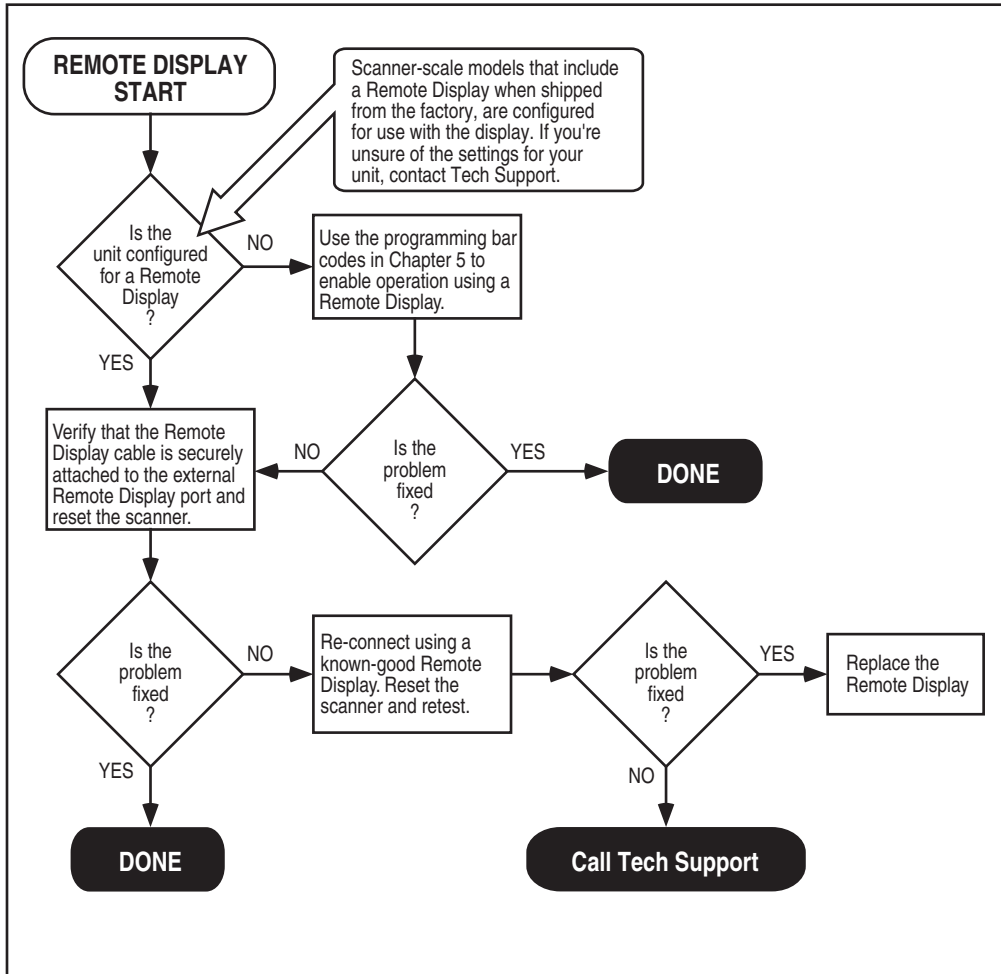

# Chapter 4

## Calibration

---

A number of situations require the scale to be calibrated. They are:

- at initial installation of the scanner/scale
- if the scale cannot be re-zeroed
- if diagnostics indicate a calibration error
- the weigh module has been replaced

Follow the procedures on the following pages to ensure that the scanner/scale will meet Weights and Measurement requirements.

### LEGAL NOTE

**Certification of the scanner/scale's weighing apparatus is subject to Federal, State and Local Weights and Measures statutes and is restricted to authorized government agencies and/or duly registered agents thereof. Anytime a scale is calibrated, it should be properly sealed with a lead and wire or paper seal before being placed into service.**

It is your responsibility to check with the appropriate authorities in your area to ensure compliance with pertinent regulations before removing any official seals or placing a newly calibrated scanner/scale into service.

---

# Description of Calibration Sequence

The Calibration Sequence sets the scale to an accurate reference point for weighing. This process involves the use of a Field Standard Weight Set (18.5-kilograms) for Metric. Once calibration has been successfully completed, the scanner/scale uses the certified weight as a reference for subsequent weighing activities.

These verification procedures follow the *U.S. National Institute of Standards and Technology 44 Handbook* guidelines for bench/counter scale installations.

If any of these tests fail to meet the required weight indications, you must calibrate the scanner/scale. Refer to the calibration procedures in this chapter for the proper procedures.

You may be required by state and/or local regulations to have procedures other than these performed by a certified technician or verification official.

Access to the calibration switch should be restricted with a paper or a wire and lead seal after the calibration has been performed if required by your local regulatory agency.



## NOTE

**The Calibration Sequence must be performed without removing the scanner/scale from its installed position.**

The following tools and supplies will be required to perform the calibration process:

- 18.5 kilogram Field Standard Weight Set<sup>1</sup>. (Metric calibration only).
- Lead/Wire or Paper Seal (as required by law).

---

1. NOTE: Throughout the calibration procedures, specific weights may be achieved by using a combination of weights from this set. eg. 10 kgs. may be made up of one 5.00 kg. and five 1.00 kg. weights.

## Motion Test

This test verifies that the scale will not 'zero' when the weighing surface of the scanner/scale is in motion.

1. Verify that the Yellow LED<sup>1</sup> is on and the Remote Display reads 0.000 kilograms.
2. Press lightly on the weigh platter of the scanner/scale with one hand and at the same time press and release the Zero Push Button on the operator's panel. The Yellow LED should turn Off and the Remote Display should not display 0.000 kilograms.
3. Remove your hand from the weighing platform and verify that the Yellow LED is On and the Remote Display reads 0.000 kilograms.

---

1. Yellow LED indications can be configured via feature programming and may not be enabled for certain functions.

---

## Preparing the Scanner/Scale for Calibration

1. Assure that the scanner/scale is stable, secure and properly installed. (Refer to [Chapter 2, Site Preparation and Installation](#), for instructions on the proper installation of the scanner/scale).
2. Power-up the scanner/scale.
3. Allow the unit to reach temperature equilibrium for at least one hour. If the scanner/scale is already at room temperature, allow at least 15 minutes for acclimatization.
4. Before performing the calibration, the scanner/scale must be pre-stressed with a weight of more than 15kg. With power turned on, place the entire weight set (including the case) on the weighing surface of the scale. The display should show an underscore and three hyphens , which is the overweight indication.
5. Remove all weight from the weighing surface and ensure that there are no obstructions in the debris chutes of the scanner/scale. See [Figure 2-5](#).



## Calibrating the Scale

1. Before proceeding, ensure that the scanner/scale has been prepared for this process by performing the preceding steps titled, [Preparing the Scanner/Scale for Calibration](#).
2. Remove the weigh platter and make sure that there are no obstructions in the debris chutes.
3. Cut and remove the seal that secures the calibration switch access cover as shown in [Figure 4-1](#). The seal may not be present if this is the initial installation of the scanner/scale.

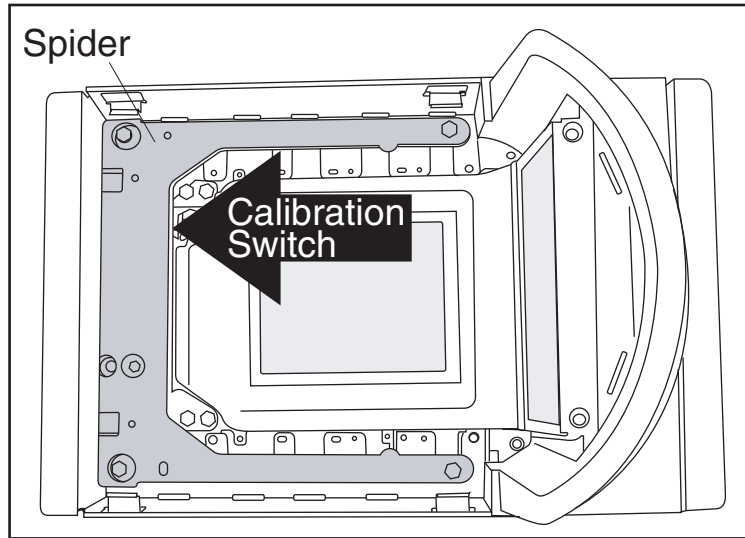

**Figure 4-1. Calibration Switch Access**

4. Press and release the Calibration Switch to place the scanner/scale in Calibration Mode. The scanner/scale will sound a tone indicating it is in Calibration Mode. If the motor was spinning when you initiated Calibration Mode, the motor will stop and the Yellow LED will begin flashing indicating the scale is in Calibration Mode. The display will show the message “ESCL” (empty scale).
5. Reinstall the weigh platter.
6. Press the Zero Push Button. The Yellow LED will go out for approximately 10 seconds (or less) and the Remote Display will alternately display - - - - and - . - . - . until the scale is ready to proceed.
7. When the scale is ready, the Yellow LED will begin blinking again and the display will show the message “Ad10 (add ten kilograms).” The scanner/scale will also sound one tone when the scale is weighing in kilograms. Place the correct weight (ten kilograms for metric calibration) from the Field Standard Weight set on the center of the weighing area and press the Zero Push Button again.

- 
8. The Yellow LED will extinguish for approximately 10 seconds and the Remote Display will alternately display  and  until the scale is ready to proceed.
  9. If the calibration was successful, the speaker sounds a single tone, the Scale Status LED begins blinking again, and “End-” appears in the Remote Display.
  10. If the calibration was not successful, the speaker will sound five tones indicating a scale failure, and the Scale Status LED will blink twice, strobe (fast blinks) and then continually repeat this sequence until reset. Remove all weight from the Weigh Platter, and repeat the procedure starting with step 7.
  11. Press the Zero Push Button again to permanently store the calibration data and exit Calibration Mode. You have completed the calibration of the scanner/scale. The unit’s calibration must now be verified as required by state and/or local weights and measures regulations. The verification procedure must be performed to assure that a scale will pass Weights and Measures requirements before it is placed into commercial/retail service.

You have completed the scale calibration procedure. You must now continue with the calibration verification tests to complete the scale’s calibration.

---

## Calibration Verification (Kilograms)

Once you have completed the calibration sequence, you may be required to perform these step-by-step verification procedures. These procedures follow the *National Institute of Standards and Technology Handbook-44* guidelines for grocery scale installations. You may be required by state or local law to have these procedures performed by a certified technician or verified by a proper official.

These calibration verification procedures cover five different tests:

- Increasing-Load Test
- Shift Test
- Blanking Test
- Decreasing-Load Test
- Return to Zero Test

### Increasing-Load Test (Phase 1)

This test checks Scale operation for increasing loads from 0.100 kg and 7.50 kg.

1. Check that the display reads 0.000 kg when at rest with nothing on the weighing surface. (The Yellow LED is steadily lit).
2. Place a 100 gram weight on the center of the weighing surface and check that the display reads 0.100 kg.
3. Place an additional 200 grams on the center of the weighing surface and check that the display reads 0.300 kg.
4. Place an additional 200 grams on the center of the weighing surface and check that the display reads 0.500 kg.
5. Place an additional 100 grams on the center of the weighing surface and check that the display reads 0.600 kg.
6. Place an additional 100 grams on the center of the weighing surface and check that the display reads 0.700 kg.
7. Place an additional 100 grams on the center of the weighing surface and check that the display reads 0.800 kg.

- 
8. Place an additional 200 grams on the center of the weighing surface and check that the display reads 1.000 kg.
  9. Increase the weight on the scale to 7.50 kg on the center of the weighing surface and check that the display reads between 7.495 and 7.505 kg.
  10. Remove the weights and verify that the display reads 0.000 kg. You have completed the Increasing-Load Test (Phase 1).

## Shift Test (Metric)

The Shift Test checks to ensure that items placed anywhere on the weighing surface of the scanner/scale are weighed properly. Refer to **Figure 4-2** when performing this test.

1. Place and remove in succession, a 5.0 kilogram load on the center of each of the four quadrants (A, B, C, and D in **Figure 4-2**) and in the center of the scanner/scale's weighing platform. Verify that the display shows a reading of between 4.995 and 5.005 kg for each quadrant/center test and that the display returns to 0.000 between each load.
2. After verifying the accuracy of each quadrant and the center of the weighing surface, remove all weight from the scale. You have completed the Shift Test.

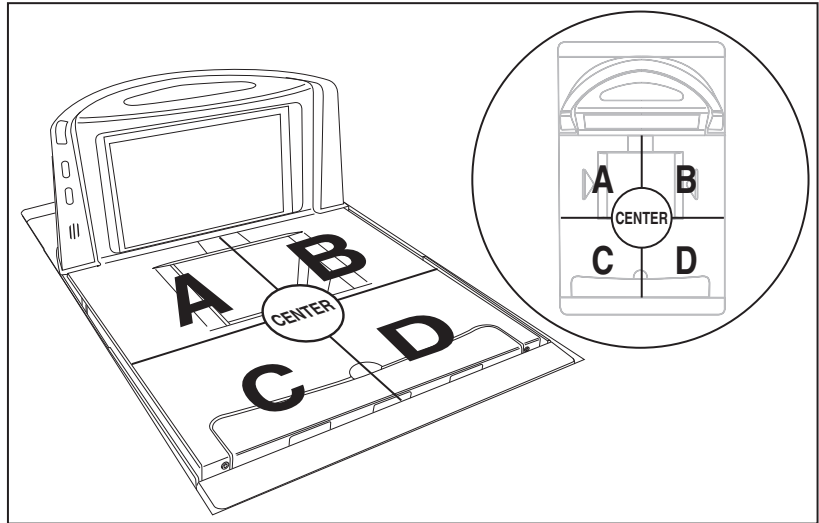
**Figure 4-2. European Shift Test (Metric)**

## Increasing- Load Test (Phase 2)

After completing the Shift Test, you must complete the Increasing Load Test using 10.00, 12.50 and 15 kilograms of weight.



### NOTE

The upper limit of the scale is configurable according to POS interface type and may not necessarily be set at 15 kilograms, which is the standard setting. For this test, continue to place weights in 2.50 kilogram increments only up to the upper weight limit set for your scale.

1. Place 10.00 kilograms in the center of the weighing surface and check that the display reads between 9.990 kg and 10.010 kg.
2. Place an additional 2.50 kilograms in the center of the weighing surface and check that the display reads between 12.490 kg and 12.510 kg.
3. Place an additional 2.50 kilograms in the center of the weighing surface and check that the display reads between 14.990 kg and 15.010 kg.
4. Remove the weights and verify that the display reads 0.000 kg.

- 
5. You have completed phase two of the increasing load test.

## Blanking Test

This test ensures that the scanner/scale will indicate its weighing capability has been exceeded if a weight greater than 0.82 over its maximum upper weight limit is placed upon the unit.

1. Place weights that total the upper limit plus 0.82 kilograms on the weigh platter. For example: If the upper limit is set at 15 kilograms, place weights equaling 15.82 kilograms.
2. Verify that the display shows a dash and three hyphens ( \_ - - - ). This is the overweight indication.



### NOTE

**The scanner/scale may blank (show an underscore and three hyphens) at any weight greater than its upper limit, but must blank when the upper limit plus 0.281 kg. are set upon the weighing surface.**

## Decreasing-Load Test

This test ensures that the scanner/scale responds properly when a heavy object is followed by a significantly smaller object.

1. Place weights that total 15.8 kilograms.



**If the upper weight limit for your scale is not set at 15 kilograms, begin by placing weight equaling your upper limit setting plus 0.8 kilograms.**

### NOTE

2. Remove weights to leave 10 kilograms on the scale and verify that the display shows between 9.990 and 10.010 kilograms.
3. Remove an additional 9.00 kilograms from the scale and check that the scale reads 1.000 kg.
4. You have completed the Decreasing Load Test.

## Return to Zero Test

This test ensures that, after all other tests have been completed successfully, the scanner/scale returns to zero. Without any weight on the weigh platter, verify that the scale reads 0.000 kg.

You have completed the calibration and verification process for weighing in kilograms.

If the scanner/scale passes all these tests,

1. Remove the weigh platter, install the calibration switch cover and install a seal (if required).
2. Reinstall the weigh platter.

If the scanner/scale fails any of these tests, it should be serviced by a qualified technician.

---

# NOTES



# Chapter 5

# Programming

---

## Entering and Exiting Programming Mode.

Use the bar code label below to enter and exit ('switch" into and out of) Programming Mode.

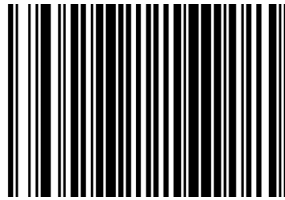

SWITCH LABEL

---

# Return to Factory Settings

Scan this bar code to return the scanner to the default settings configured at the factory for the currently active interface. This bar code is typically used to return the scanner to a “known” operating state when the present programming status is not known, faulty, or suspect.



**Use this bar code with caution, since it will reset ALL features that may have been programmed since the scanner’s installation.**

## CAUTION



**DO NOT scan the SWITCH bar code before and after scanning this bar code, as the bar code below automatically enters and exits Programming Mode as a part of its function. If this bar code is scanned following a SWITCH bar code, it will simply cause the scanner to exit Programming Mode without making changes.**

## NOTE

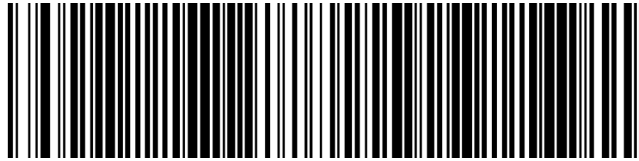

RETURN TO FACTORY SETTINGS

# Scale Features

## Scale Enable



### NOTE

Use this feature to enable or disable scale operation.

**Recalibration/recertification may be required when adding scale functionality. Consult your local Weights and Measures authority.**

**If this feature is enabled the scanner will expect that it is to function as a scanner-scale, and will indicate an error if it is not a scale-equipped unit. See Chapter 3, Error Codes, for more information.**

To set this feature:

1. Scan the SWITCH bar code.
2. Scan your selection from the two bar codes below. You'll need to cover any unused bar codes on this and the facing page to ensure that the scanner reads only the bar code you intend to scan.
3. Complete the programming sequence by scanning the SWITCH bar code.



SCALE = DISABLE



SCALE = ENABLE

---

## Scale Enforced Zero Return

This feature enables/disables the enforced zero return of the scale. Three settings are available for this feature:

- Disable
- Scale Must Return to Zero Weight Within Two Minutes — Scale will require re-zeroing if a non-zero weight is left on for more than two minutes or if the scale is below zero.
- Scale Must Return to Zero Weight Between Weight Requests — Re-zeroing is required if weight doesn't return to zero between weight requests from the POS, plus scale will require re-zeroing if a non-zero weight is left on for more than two minutes or if the scale is below zero.
- Non-Zero for Two Minutes — Re-zeroing is required if weight does not return to zero within two minutes.

To set this feature:

1. Scan the SWITCH bar code.
2. Scan your selection from the bar codes below. You'll need to cover any unused bar codes on this and the facing page to ensure that the scanner reads only the bar code you intend to scan. The strategy is to select the lowest possible filter level needed that allows normal scale operation.
3. Complete the programming sequence by scanning the SWITCH bar code.



SCALE ENFORCED ZERO RETURN = DISABLE

---

## Scale Enforced Zero Return — continued

Remember to cover any unused bar codes on this and the facing page to ensure that the scanner reads only the bar code you intend to scan.



SCALE ENFORCED ZERO RETURN =  
NON-ZERO FOR 2 MINUTES OR BELOW ZERO



SCALE ENFORCED ZERO RETURN = NON-ZERO FOR 2 MINUTES OR BELOW  
ZERO OR NO ZERO BETWEEN WEIGHTS

---

## Scale Enforced Zero Return — continued

Remember to cover any unused bar codes on this and the facing page to ensure that the scanner reads only the bar code you intend to scan.



SCALE ENFORCED ZERO RETURN =  
NON-ZERO FOR 2 MINUTES

## Scale Interface Type

Use this feature to select the scale interface type. Choices are:

- No Scale Interface
- RS-232 — SASI
- RS-232 — ICL

To set the Scale Interface Type:

1. Scan the SWITCH bar code.
2. Scan your selection from the bar codes below. You'll need to cover any unused bar codes on this and the facing page to ensure that the scanner reads only the bar code you intend to scan.
3. Complete the programming sequence by scanning the SWITCH bar code.



SCALE INTERFACE TYPE = NO SCALE INTERFACE



SCALE INTERFACE TYPE = RS-232 — SASI

---

## Scale Interface Type — continued

Remember to cover any unused bar codes on this and the facing page to ensure that the scanner reads only the bar code you intend to scan.



SCALE INTERFACE TYPE = RS-232 — ICL



---

## Scale Calibration Notification

When enabled, this feature allows the host to be notified of a calibration event.

To set this feature:

1. Scan the SWITCH bar code.
2. Scan your selection from the two bar codes below. You'll need to cover any unused bar codes on this and the facing page to ensure that the scanner reads only the bar code you intend to scan.
3. Complete the programming sequence by scanning the SWITCH bar code.



SCALE CALIBRATION NOTIFICATION = DISABLE



SCALE CALIBRATION NOTIFICATION = ENABLE

---

## Scale Intercharacter Delay

Sets the delay between the end of one character and the beginning of the next, in 10 millisecond increments.

To specify the intercharacter delay:

1. Scan the SWITCH bar code.
2. Scan the bar code below, **SCALE INTERCHARACTER DELAY**. You'll need to cover any unused bar codes on this and the facing page to ensure that the scanner reads only the bar code you intend to scan.
3. Scan the appropriate digits from the keypad in **Appendix A** that represent the desired delay. The selectable range is 0-100, which is the delay in 10-millisecond increments. Pad all single and double digit numbers with leading zeroes to yield a three-digit entry (000-100).

Examples:

001 = 10ms

005 = 50ms

040 = 400ms

100 = 1,000ms (1 second)

4. The scanner will automatically exit Programming Mode when the appropriate amount of digits have been scanned.



SCALE INTERCHARACTER DELAY

## Remote Display — Enable/Disable

The scanner-scale can be configured to operate with or without a Remote Display.



**Recalibration/recertification may be required when adding a Remote Display. Consult your local Weights and Measures authority.**

### NOTE

If this feature is enabled the scanner-scale will expect that it is connected to a Remote Display, and will indicate an error if one is not. See Chapter 3, [Error Codes](#), for more information.



REMOTE DISPLAY = DISABLE



REMOTE DISPLAY = ENABLE

---

# Interface Related Features

## Interface Type

Specifies the current scanner interface.

INTERFACE (I/F) TYPE	I/F I.D. NUMBER <sup>a</sup>
RS-232 Standard	05
RS-232 Wincor-Nixdorf	12
RS-232 Single Cable	20
IBM USB	45
IBM Port 17	04
<b>NOT USER-SELECTABLE</b>	
Null Interface	7-segment FRU display indicates 0 at start-up (accompanied by trill beep for approx. 2 seconds)

<sup>a.</sup> To access a scanner's interface identification number, place the scanner in Scanner Diagnostic Mode and view the 7-segment FRU display.

## Interface Type — continued



### NOTE

A new scanner may have been shipped from the factory with a Null Interface (no interface type selected) to ensure system compatibility at installation. In this case, the correct Interface Type programming bar code must be scanned first before the scanner can be used with a POS system.



### NOTE

If the scanner's interface type must be changed, always be sure that interface configuration is the **FIRST** item scanned during a programming session. (Selecting an interface type resets **ALL** other configuration items to the factory default for that interface type.)

To select the desired interface:



### CAUTION

Great care should be taken to select the correct interface type, since you can cause damage to the scanner and/or POS terminal by attempting to change to an incompatible interface. **ALWAYS** make interface selections with the host cable **DISCONNECTED**.



### NOTE

When an interface is selected, the scanner loads the factory configuration for that interface as the selection is made, erasing any and all custom configuration that may have previously been done.

1. Disconnect current interface cable(s) if currently connected.
2. Scan the SWITCH bar code
3. Scan the bar code representing the appropriate interface located on the following pages. You'll need to cover any unused bar codes adjacent to and on any facing pages to ensure the scanner reads only the bar code you intend to scan.

---

## Interface Type — continued

4. Complete the programming sequence by scanning the SWITCH bar code.



### NOTE

Once the correct interface has been set, it will be necessary to proceed to the appropriate pages in this manual that select parameters and options for that interface. For example, if RS-232 is selected, turn to the pages in this manual headed as features specific to the RS-232 interface.

5. Connect new interface cable(s).

### RS-232 Interface Selection

Remember to cover any unused bar codes on this and the facing page to ensure that the scanner reads only the bar code you intend to scan.



### CAUTION

Great care should be taken to select the correct interface type, since you can cause damage to the scanner and/or POS terminal by attempting to change to an incompatible interface. **ALWAYS** make interface selections with the host cable **DISCONNECTED**.



INTERFACE TYPE = RS-232 STANDARD

## RS-232 Wincor-Nixdorf Interface Selection

Remember to cover any unused bar codes on this and the facing page to ensure that the scanner reads only the bar code you intend to scan.



**CAUTION**

**Great care should be taken to select the correct interface type, since you can cause damage to the scanner and/or POS terminal by attempting to change to an incompatible interface. ALWAYS make interface selections with the host cable DISCONNECTED.**



INTERFACE TYPE = RS-232 WINCOR-NIXDORF

---

## RS-232 Single Cable Interface Selection

Remember to cover any unused bar codes on this and the facing page to ensure that the scanner reads only the bar code you intend to scan.



**CAUTION**

Great care should be taken to select the correct interface type, since you can cause damage to the scanner and/or POS terminal by attempting to change to an incompatible interface. **ALWAYS** make interface selections with the host cable **DISCONNECTED**.



**NOTE**

Single cable installations require connection at the POS Terminal (host) port. The Scale Host port connection is not used for this interface.



INTERFACE TYPE = RS-232 SINGLE CABLE



## IBM USB Interface Selection

Remember to cover any unused bar codes on this and the facing page to ensure that the scanner reads only the bar code you intend to scan.



### CAUTION

Great care should be taken to select the correct interface type, since you can cause damage to the scanner and/or POS terminal by attempting to change to an incompatible interface. **ALWAYS** make interface selections with the host cable **DISCONNECTED**.



### NOTE

Single cable installations require connection at the POS Terminal (host) port. The Scale Host port connection is not used for this interface.



INTERFACE TYPE = IBM USB

---

## IBM Port 17 Interface Selection

Remember to cover any unused bar codes on this and the facing page to ensure that the scanner reads only the bar code you intend to scan.



### CAUTION

Great care should be taken to select the correct interface type, since you can cause damage to the scanner and/or POS terminal by attempting to change to an incompatible interface. **ALWAYS** make interface selections with the host cable **DISCONNECTED**.



### NOTE

Single cable installations require connection at the POS Terminal (host) port. The Scale Host port connection is not used for this interface.



INTERFACE TYPE = IBM Port 17

# NOTES

---

# NOTES

# Appendix A

## Keypad

---

Use the bar codes in this appendix to enter numbers and characters as you would select digits/characters from a keypad.

Scan your selection from the bar codes below. You'll need to cover any unused bar codes on this and the facing page to ensure that the scanner reads only the bar code you intend to scan.



0



1

---

Use the bar codes in this appendix to enter numbers and characters as you would select digits/characters from a keypad.

Scan your selection from the bar codes below. You'll need to cover any unused bar codes on this and the facing page to ensure that the scanner reads only the bar code you intend to scan.



2



3

---

Use the bar codes in this appendix to enter numbers and characters as you would select digits/characters from a keypad.

Scan your selection from the bar codes below. You'll need to cover any unused bar codes on this and the facing page to ensure that the scanner reads only the bar code you intend to scan.



4



5

---

Use the bar codes in this appendix to enter numbers and characters as you would select digits/characters from a keypad.

Scan your selection from the bar codes below. You'll need to cover any unused bar codes on this and the facing page to ensure that the scanner reads only the bar code you intend to scan.



6



7



---

Use the bar codes in this appendix to enter numbers and characters as you would select digits/characters from a keypad.

Scan your selection from the bar codes below. You'll need to cover any unused bar codes on this and the facing page to ensure that the scanner reads only the bar code you intend to scan.



8



9

---

Use the bar codes in this appendix to enter numbers and characters as you would select digits/characters from a keypad.

Scan your selection from the bar codes below. You'll need to cover any unused bar codes on this and the facing page to ensure that the scanner reads only the bar code you intend to scan.



A



B

---

Use the bar codes in this appendix to enter numbers and characters as you would select digits/characters from a keypad.

Scan your selection from the bar codes below. You'll need to cover any unused bar codes on this and the facing page to ensure that the scanner reads only the bar code you intend to scan.



C



D

---

Use the bar codes in this appendix to enter numbers and characters as you would select digits/characters from a keypad.

Scan your selection from the bar codes below. You'll need to cover any unused bar codes on this and the facing page to ensure that the scanner reads only the bar code you intend to scan.



E



F

# ASCII Character Set

The table on this page shows a set of ASCII characters and their corresponding Hex Values. The Hex Values in this table are needed for setting symbology specific label identifiers, as well as enabling custom prefix and suffix characters.

ASCII Char.	Hex No.	ASCII Char.	Hex No.	ASCII Char.	Hex No.	ASCII Char.	Hex No.
NUL	00	SP	20	@	40	'	60
SOH	01	!	21	A	41	a	61
STX	02	"	22	B	42	b	62
ETX	03	#	23	C	43	c	63
EOT	04	\$	24	D	44	d	64
ENQ	05	%	25	E	45	e	65
ACK	06	&	26	F	46	f	66
BEL	07	'	27	G	47	g	67
BS	08	(	28	H	48	h	68
HT	09	)	29	I	49	i	69
LF	0A	*	2A	J	4A	j	6A
VT	0B	+	2B	K	4B	k	6B
FF	0C	,	2C	L	4C	l	6C
CR	0D	-	2D	M	4D	m	6D
SO	0E	.	2E	N	4E	n	6E
SI	0F	/	2F	O	4F	o	6F
DLE	10	0	30	P	50	p	70
DC1	11	1	31	Q	51	q	71
DC2	12	2	32	R	52	r	72
DC3	13	3	33	S	53	s	73
DC4	14	4	34	T	54	t	74
NAK	15	5	35	U	55	u	75
SYN	16	6	36	V	56	v	76
ETB	17	7	37	W	57	w	77
CAN	18	8	38	X	58	x	78
EM	19	9	39	Y	59	y	79
SUB	1A	:	3A	Z	5A	z	7A
ESC	1B	;	3B	[	5B	{	7B
FS	1C	<	3C	\	5C		7C
GS	1D	=	3D	]	5D	}	7D
RS	1E	>	3E	^	5E	~	7E
US	1F	?	3F	_	5F	DEL	7F

**Australia**

Datalogic Scanning Pty Ltd  
Telephone: [61] (2) 9870 3200  
australia.scanning@datalogic.com

**Japan**

Datalogic Scanning KK  
Telephone: 81 (0)3 3491 6761  
japan.scanning@datalogic.com

**France and Benelux**

Datalogic Scanning SAS  
Telephone: [33].01.64.86.71.00  
france.scanning@datalogic.com

**Latin America**

Datalogic Scanning, Inc  
Telephone: (305) 591-3222  
latinamerica.scanning@datalogic.com

**Germany**

Datalogic Scanning GmbH  
Telephone: 49 (0) 61 51/93 58-0  
germany.scanning@datalogic.com

**Singapore**

Datalogic Scanning Singapore PTE LTD  
Telephone: (65) 6435-1311  
singapore.scanning@datalogic.com

**India**

Datalogic Scanning India  
Telephone: 91- 22 - 64504739  
india.scanning@datalogic.com

**Iberia**

Datalogic Scanning SAS Sucursal en España  
Telephone: 34 91 746 28 60  
spain.scanning@datalogic.com

**Italy**

Datalogic Scanning SpA  
Telephone: [39] (0) 39/62903.1  
italy.scanning@datalogic.com

**United Kingdom**

Datalogic Scanning LTD  
Telephone: 44 (0) 1582 464900  
uk.scanning@datalogic.com



[www.scanning.datalogic.com](http://www.scanning.datalogic.com)

**Datalogic Scanning, Inc.**

959 Terry Street  
Eugene, OR 97402  
USA  
Telephone: (541) 683-5700  
Fax: (541) 345-7140

