

The Intermec logo is displayed in a bold, italicized, sans-serif font. It is positioned on the left side of the page, partially overlapping a large, light gray circular graphic that features several overlapping loops and a small solid gray circle at one of the intersections.

Intermec



Installation Instructions

Cutter Kit

for the EasyCoder®

PD41 and PD42 Printers

Intermec Technologies Corporation
Worldwide Headquarters
6001 36th Ave. W.
Everett, WA 98203
U.S.A.
www.intermec.com

The information contained herein is provided solely for the purpose of allowing customers to operate and service Intermec-manufactured equipment and is not to be released, reproduced, or used for any other purpose without written permission of Intermec Technologies Corporation.

Information and specifications contained in this document are subject to change without prior notice and do not represent a commitment on the part of Intermec Technologies Corporation.

© 2005-2007 by Intermec Technologies Corporation. All rights reserved.

The word Intermec, the Intermec logo, Norand, ArciTech, Beverage Routebook, CrossBar, dcBrowser, Duratherm, EasyADC, EasyCoder, EasySet, Fingerprint, INCA (under license), i-gistics, Intellitag, Intellitag Gen2, JANUS, LabelShop, MobileLAN, Picolink, Ready-to-Work, RoutePower, Sabre, ScanPlus, ShopScan, Smart Mobile Computing, SmartSystems, TE 2000, Trakker Antares, and Vista Powered are either trademarks or registered trademarks of Intermec Technologies Corporation.

There are U.S. and foreign patents as well as U.S. and foreign patents pending.

Installing the Cutter

- 1 Unpack your cutter kit and check that all parts depicted below are included. If not, contact your Intermec sales representative.

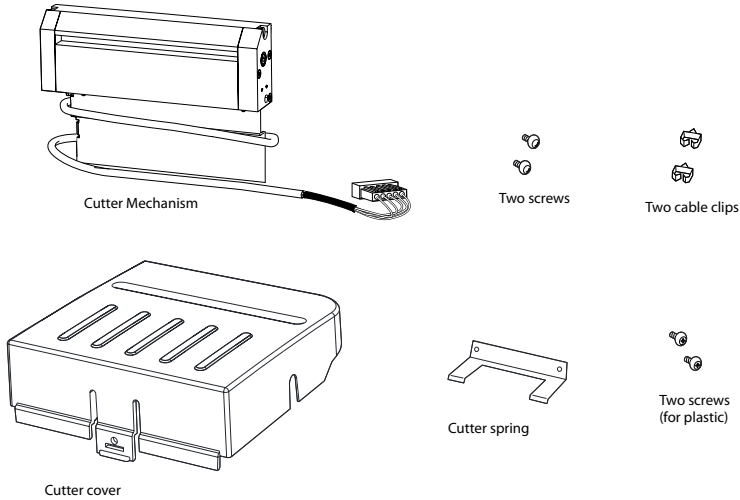

- 2 Make sure the printer is turned off and disconnected from the power supply. Remove the screw that holds the front cover. Remove the front cover.

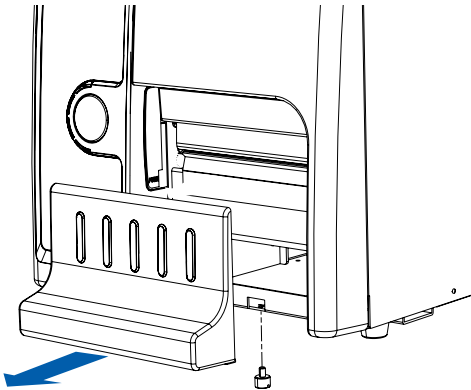

- 3** Open the side door and remove the tear bar, held by two Phillips screws.

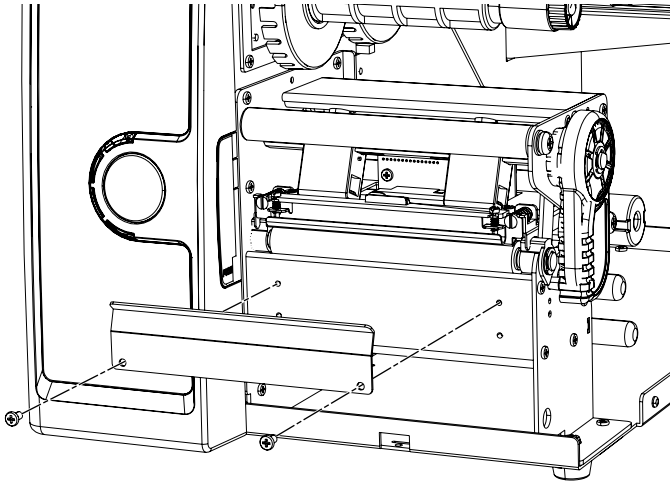

- 4** Attach the cutter mechanism to the printer using the two Phillips screws included in the kit.

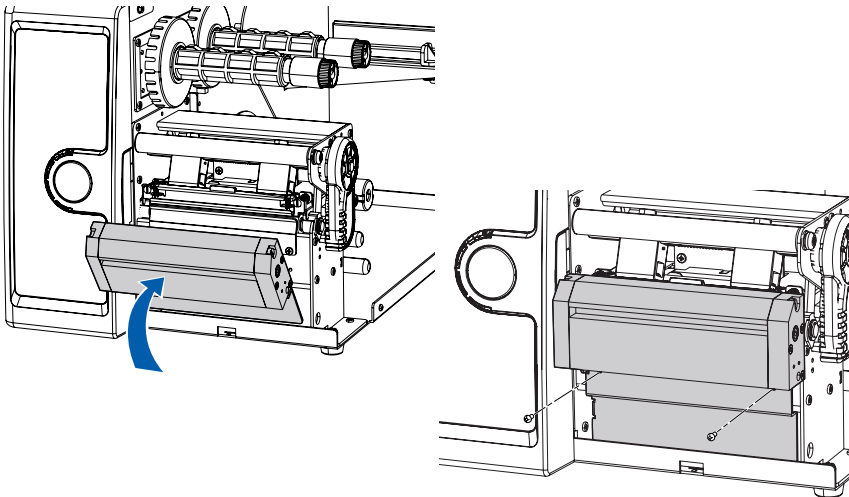

- 5 Plug the cutter cable into the connector in the center section as shown. Secure the cable to the bottom plate using the two cable clips included in the kit.

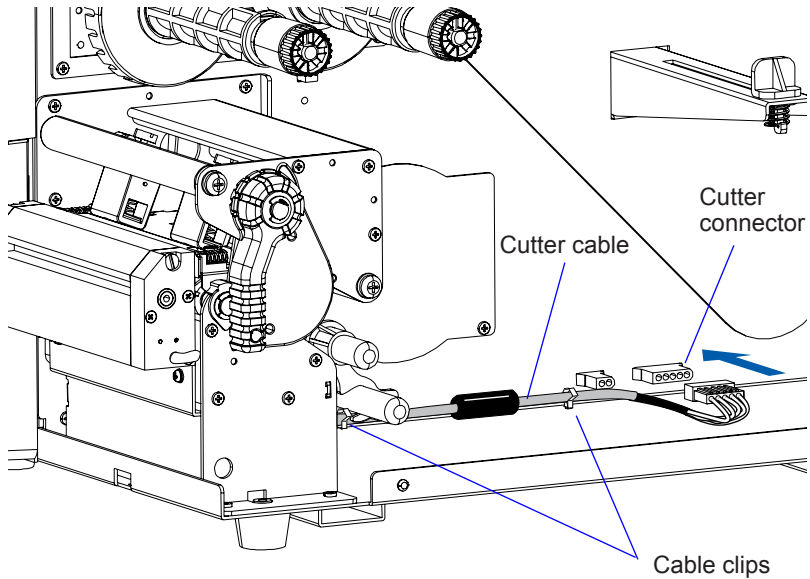

- 6 Use the two plastic screws to attach the cutter spring to the cover (1). Hook the cutter cover onto the cutter mechanism and lock the cover with the screw at the bottom (2).

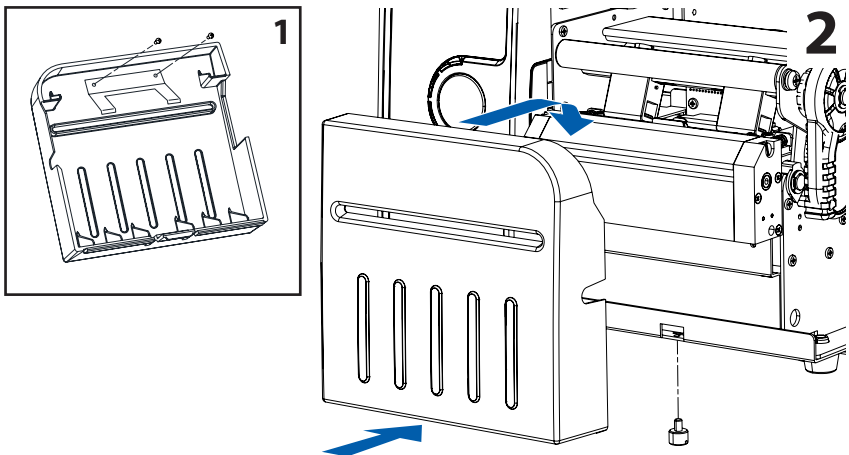

Activating the Cutter (PD42 only)

If you are using a PD42 printer you can activate the cutter directly from the display.

To activate the cutter on a PD42 printer

- 1 Turn the printer on.
- 2 Press **Setup** (⚙️).
- 3 Navigate to **Configuration** > **Cutter** > **Enable**.
- 4 Press **Acknowledge** (←).
- 5 Press **Setup** again to exit setup.

Controlling the Cutter (Fingerprint)

The cutter function is controlled with the Fingerprint commands CUT and CUT ON/OFF. Please refer to the *Fingerprint Programmer's Reference Manual* (P/N 937-005-xxx) for more information.

Controlling the Cutter (IPL)

The cutter function is controlled with the IPL commands listed below. Please refer to the *IPL Programmer's Reference Manual* (P/N 066396-xxx) for more information.

IPL Cutter Commands

Command	Description
<SO>	Cut
<SI>c1	Enable cutter
<SI>c0	Disable cutter

Installing Media

To install media in the printer, follow the instructions provided in the printer's user's guide. The cutter is primarily intended to cut paper-based media in the form of continuous stock. To obtain optimal use of the cutter, make sure your media corresponds to the specification below.

Recommended minimum label/paper length	30 mm
Maximum label/paper width	114 mm
Recommended media thickness	78 - 175 μm



Configure your cutter so that it only cuts through the label liner. If you cut through both label and liner, the adhesive sticks to the cutting blade and this causes malfunction. Also avoid cutting soft, plastic-based media.



Intermec Technologies Corporation

Worldwide Headquarters
6001 36th Avenue West
Everett, WA 98203
U.S.A.

tel 425.348.2600

fax 425.355.9551

www.intermec.com

EasyCoder PD41/PD42 Cutter Kit Installation Instructions



P/N 1-960657-01