

# PX4i | PX6i

Print Kit

**Integration Guide**

Intermec Technologies Corporation

Worldwide Headquarters

6001 36th Ave.W.

Everett, WA 98203

U.S.A.

[www.intermec.com](http://www.intermec.com)

The information contained herein is provided solely for the purpose of allowing customers to operate and service Intermec-manufactured equipment and is not to be released, reproduced, or used for any other purpose without written permission of Intermec Technologies Corporation.

Information and specifications contained in this document are subject to change without prior notice and do not represent a commitment on the part of Intermec Technologies Corporation.

© 2011 by Intermec Technologies Corporation. All rights reserved.

The word Intermec, the Intermec logo, Norand, ArciTech, Beverage Routebook, CrossBar, dcBrowser, Duratherm, EasyADC, EasyCoder, EasySet, Fingerprint, i-gistics, INCA (under license), Intellitag, Intellitag Gen2, JANUS, LabelShop, MobileLAN, Picolink, Ready-to-Work, RoutePower, Sabre, ScanPlus, ShopScan, Smart Mobile Computing, SmartSystems, TE 2000, Trakker Antares, and Vista Powered are either trademarks or registered trademarks of Intermec Technologies Corporation.

There are U.S. and foreign patents as well as U.S. and foreign patents pending.

# Contents

Before You Begin.....	v
Global Services and Support.....	v
Warranty Information.....	v
Web Support.....	v
Telephone Support.....	v
Service Location Support.....	v
Who Should Read This Manual.....	vi
Related Documents.....	vi
About This Integration Guide.....	9
About the PX4i and PX6i Print Kits.....	9
About the Print Kit Parts.....	10
Main Logic Board.....	10
Power Supply and Driver Board.....	10
Print Module.....	11
Keypad and Display Assembly.....	12
About the Option Kits.....	13
About the Parts in Option Kit 1.....	14
Ribbon Supply Unit.....	14
Ribbon Rewind Unit.....	15
Ribbon Sensor.....	15
About the Parts in Option Kit 2.....	15
3-Inch Adapter.....	15
Media Supply Hub.....	16
Guide Plate.....	16
Label Slack Absorber.....	17
About the Parts in Option Kit 3.....	17
Liner Takeup Unit.....	17
Brace.....	18
Break Shaft.....	18
Stepper Motor.....	18
Motor Mount.....	19
Belt Stretcher Kit.....	19
About the Parts in Option Kit 4.....	19

**Contents**

# Before You Begin

This section provides you with technical support information and sources for additional product information.

## Global Services and Support

### Warranty Information

To understand the warranty for your Intermec product, visit the Intermec web site at [www.intermec.com](http://www.intermec.com) and click **Support > Returns and Repairs > Warranty**.

Disclaimer of warranties: The sample code included in this document is presented for reference only. The code does not necessarily represent complete, tested programs. The code is provided “as is with all faults.” All warranties are expressly disclaimed, including the implied warranties of merchantability and fitness for a particular purpose.

### Web Support

Visit the Intermec web site at [www.intermec.com](http://www.intermec.com) to download our current manuals (in PDF).

Visit the Intermec technical knowledge base (Knowledge Central) at [www.intermec.com](http://www.intermec.com) and click **Support > Knowledge Central** to review technical information or to request technical support for your Intermec product.

### Telephone Support

In the U.S.A. and Canada, call **1-800-755-5505**.

Outside the U.S.A. and Canada, contact your local Intermec representative. To search for your local representative, from the Intermec web site, click **About Us > Contact Us**.

### Service Location Support

For the most current listing of service locations, go to [www.intermec.com](http://www.intermec.com) and click **Support > Returns and Repairs > Repair Locations**.

For technical support in South Korea, use the after service locations listed below:

**Awoo Systems**

102-1304 SK Ventium  
522 Dangjung-dong  
Gunpo-si, Gyeonggi-do Korea, South 435-776  
Contact: Mr. Sinbum Kang  
Telephone: +82-31-436-1191  
E-mail: [mjyun@awoo.co.kr](mailto:mjyun@awoo.co.kr)

**IN Information System PTD LTD**

6th Floor  
Daegu Venture Center Bldg 95  
Shinchun 3 Dong  
Donggu, Daegu City, Korea  
E-mail: [jmyou@idif.co.kr](mailto:jmyou@idif.co.kr) or [korlim@gw.idif.co.kr](mailto:korlim@gw.idif.co.kr)

## Who Should Read This Manual

This document provides you with information about the features of components in the PX4i and PX6i Print Kits, and is intended for the person responsible for evaluating Print Kit components for use in a custom print applicator system.

## Related Documents

Here are some related Intermec documents you might find useful:

- *[PX4i and PX6i High Performance Printer User's Manual](#)*
- *[Intermec Fingerprint Command Reference Manual](#)*
- *[Intermec Fingerprint Developer's Guide](#)*

The Intermec web site at [www.intermec.com](http://www.intermec.com) contains our documents (as .pdf files) that you can download for free.

### To download documents

- 1 Visit the Intermec web site at [www.intermec.com](http://www.intermec.com).
- 2 Click the **Products** tab.
- 3 Using the **Products** menu, navigate to your product page. For example, to find the PX4i printer product page, click **Printers and Media > Fixed Printers > PX4i**.
- 4 Click the **Manuals** tab.

If your product does not have its own product page, click **Support > Manuals**. Use the **Product Category** field, the **Product Family** field, and the **Product** field to help you locate the documentation for your product.

***Before You Begin***



# About This Integration Guide

This Guide explains the functions of each of the components in the PX4i and PX6i Print Kits and Option Kits. For more information on integrating Print Kit components, contact your Intermec sales representative.

## About the PX4i and PX6i Print Kits

The PX4i and PX6i Print Kits include Intermec printer components you can use in your custom print engine hardware.



**Note:** PX4i kits include hardware for media widths up to 101.6 mm (4 inches). PX6i kits include hardware for media widths up to 152.4 mm (6 inches).

All Base 1 Print Kits include:

- a print module with either a 203-dpi or 300-dpi printhead.
- a main logic board for controlling the print hardware and communicating with your controller.
- an AC power supply and driver board.

Base 2 kits also include a keyboard and 2-line display for printer messages and information.

For more information, see [“About the Print Kit Parts” on page 10](#).

### ***PX4 and PX6 Print Kit Part Numbers***

Kit Name	Part Number	Printhead	Max. Media Width
PX4i Print Kit (Base 1)	1-PX4653-04x	203 dpi	101.6 mm (4 in)
PX4i Print Kit (Base 1)	1-PX4653-05x	300 dpi	101.6 mm (4 in)
PX4i Print Kit (Base 2)	1-PX4653-06x	203 dpi	101.6 mm (4 in)
PX4i Print Kit (Base 2)	1-PX4653-07x	300 dpi	101.6 mm (4 in)
PX6i Print Kit (Base 1)	1-PX6653-04x	203 dpi	152.4 mm (6 in)
PX6i Print Kit (Base 1)	1-PX6653-05x	300 dpi	152.4 mm (6 in)
PX6i Print Kit (Base 2)	1-PX6653-06x	203 dpi	152.4 mm (6 in)
PX6i Print Kit (Base 2)	1-PX6653-07x	300 dpi	152.4 mm (6 in)

## About the Print Kit Parts

### Main Logic Board

The main logic board (P/N 1-971156-9xx) includes a 96 MHz processor featuring an integrated SDRAM controller, PCI bridge, DMA, UART, and timers.

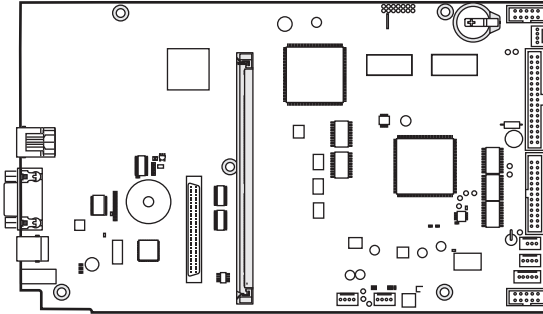

**Main Logic Board:** Appearance varies depending on part version.

### Power Supply and Driver Board

The power supply (P/N 1-971132-9xx) delivers 24 VDC to the driver board. AC power input voltage range is 90 to 265 VAC, 45-65 Hz. Voltage and temperature are monitored and the supply is over-current protected.

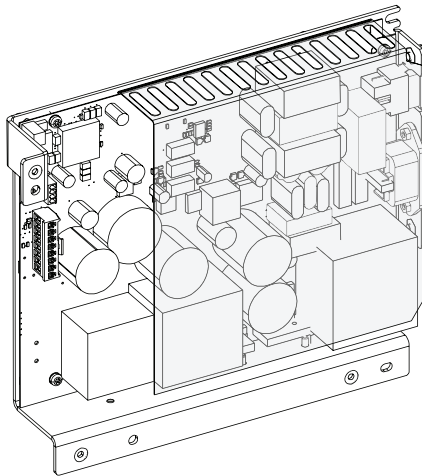

**Power Supply**

The driver board (P/N 1-971152-9xx) converts 24 VDC from the power supply to the voltages needed by other printer components. This board connects to P2 and P3 on the power supply board.

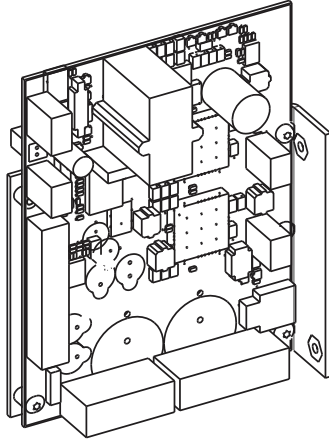

**Driver Board**

## **Print Module**

The print module (4-inch: P/N 1-040086-9xx, or 6-inch: P/N 1-040087-9xx) includes a 203-dpi or 300-dpi printhead, a stepper motor that drives the rollers, a tear bar, and a label stop sensor that controls media feed.

The stepper motor connects to P10 on the driver board.

The lower label stop sensor connects to J54 on the main logic board.  
The upper label stop sensor connects to J55 on the main logic board.

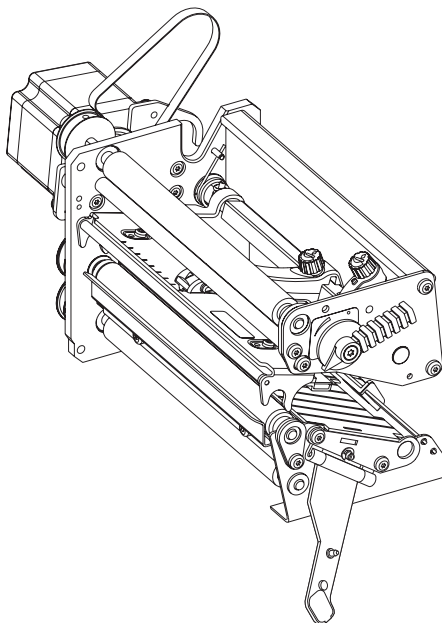

**Print Module:** Appearance varies depending on printhead and media width.

### **Printhead Part Numbers and Descriptions**

Printhead P/N	Printhead Size	Maximum Media Width
1-040082-9xx	203 dpi	101.6 mm (4 in)
1-040083-9xx	300 dpi	101.6 mm (4 in)
1-040084-9xx	203 dpi	152.4 mm (6 in)
1-040085-9xx	300 dpi	152.4 mm (6 in)



**Note:** You can also order a 400-dpi printhead (P/N 850-812-9xx) to use with the PX4i and PX6i Print Kits. For information, contact your Intermecc sales representative.

### **Keypad and Display Assembly**

The optional keypad and display assembly (P/N 1-040197-xx) includes a self-adhesive membrane switch keyboard, a self-adhesive overlay, and a printed circuit board. The entire assembly connects to J50 on the main logic board.

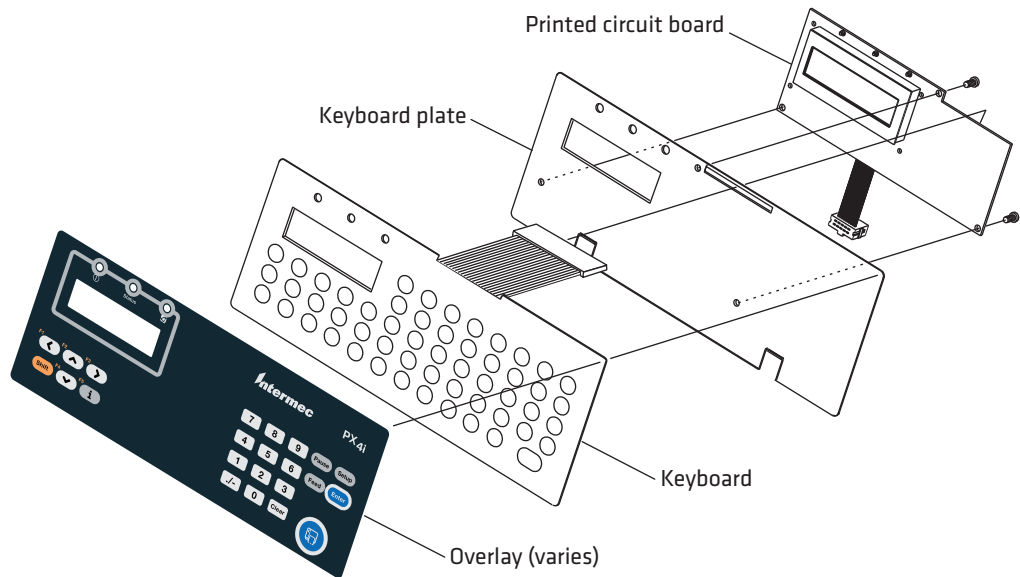

### **Keypad and Display Assembly**

The membrane switch keyboard includes 54 keys. The Shift key provides dual functionality for each key. The keyboard connects to J2 on the printed circuit board.

The self-adhesive overlay shows key locations on the keyboard. You can use your own overlays for custom applications if needed.

The printed circuit board includes a 2-line LCD and three LEDs. The backlit LCD can display 16 characters (5 x 7 dots) in each line. The three LEDs indicate power, printer status, and Intermec Ready-to-Work state.

## **About the Option Kits**

Option Kits 1, 2, and 3 include the necessary hardware for handling different types of media:

- Option Kit 1 includes hardware for use with thermal transfer ribbon. For more information, see **“About the Parts in Option Kit 1” on page 14.**
- Option Kit 2 includes media supply hub hardware. For more information, see **“About the Parts in Option Kit 2” on page 15.**

- Option Kit 3 includes hardware for self-strip printing. For more information, see **“About the Parts in Option Kit 3” on page 17.**

Option Kit 4 includes printer cabinet center, back, and bottom plates. For more information, see **“About the Parts in Option Kit 4” on page 19.**

### **PX Option Kit Part Numbers**

<b>Kit Name</b>	<b>Part Number</b>	<b>Max. Media Width</b>
PX4i Option Kit 1	1-PX4654-00x	101.6 mm (4 in)
PX4i Option Kit 2	1-PX4654-01x	101.6 mm (4 in)
PX4i Option Kit 3	1-PX4654-02x	101.6 mm (4 in)
PX4i Option Kit 4	1-PX4654-04x	101.6 mm (4 in)
PX6i Option Kit 1	1-PX6654-00x	152.4 mm (6 in)
PX6i Option Kit 2	1-PX6654-01x	152.4 mm (6 in)
PX6i Option Kit 3	1-PX6654-02x	152.4 mm (6 in)
PX6i Option Kit 4	1-PX6654-04x	152.4 mm (6 in)

## **About the Parts in Option Kit 1**

Option Kit 1 includes components for supplying thermal transfer ribbon to the print mechanism.

### **Ribbon Supply Unit**

The ribbon supply unit (P/N 1-040189-xx) keeps the ribbon tight to prevent wrinkling and creasing. The adjustable hub fits different ribbon widths. Use two M4 x 8 mm Torx screws (supplied) to mount the ribbon supply unit to your printer chassis.

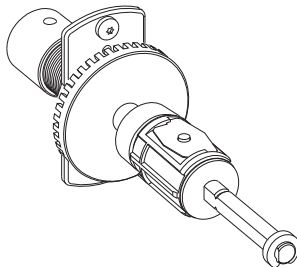

**Ribbon Supply Unit**

## Ribbon Rewind Unit

The ribbon rewind unit (P/N 1-040191-xx) is powered by the print module, and rewinds used ribbon. A friction brake keeps ribbon tight as it is rewound. Use two M4 x 8 mm Torx screws (supplied) to mount the ribbon rewind unit to your printer chassis. The ribbon rewind unit includes a belt and a tension adjust gear and axle.

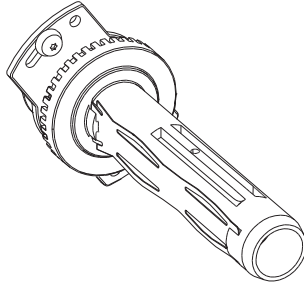

**Ribbon Rewind Unit**

## Ribbon Sensor

The ribbon sensor (P/N 1-974005-xx) determines when the ribbon supply is running low, and must be mounted at a specific location for proper operation. The sensor connects to J56 on the main logic board. Use the supplied M3 x 6 mm Torx screw to mount the sensor to your printer chassis.

## About the Parts in Option Kit 2

Option Kit 2 includes components for supplying media to the print mechanism.

## 3-Inch Adapter

The adapter (P/N 1-040327-xx) slides onto the media supply hub. Use this adapter for media roll cores of 80 mm (3 in) or larger.

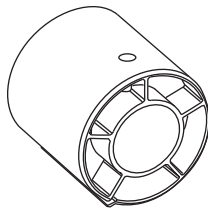

**3-Inch Adapter**

## Media Supply Hub

The media supply hub (1-040060-xx) holds media rolls for the print module. Media roll cores of up to 40 mm (1.5 inches) can fit on the hub. For a PX4 hub, the maximum media width is 120 mm (4.72 in), and for a PX6 hub, the maximum width is 170 mm (6.69 in). Use four M4 x 8 mm Torx screws (supplied) to mount the media supply hub to your printer chassis.

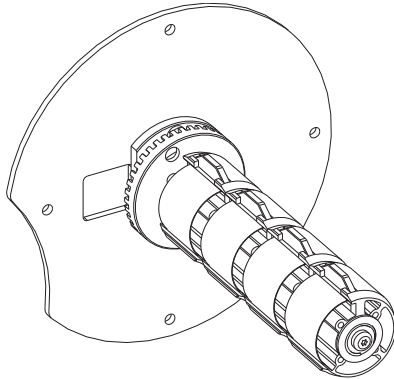

### **Media Supply Hub**

## Guide Plate

When the print mechanism and the media supply hub are mounted on the same chassis panel, the guide plate (P/N 1-040296-xx) keeps the media correctly aligned with the print mechanism. Use three M4 x 8 mm Torx screws (supplied) to mount the guide plate to your printer chassis.

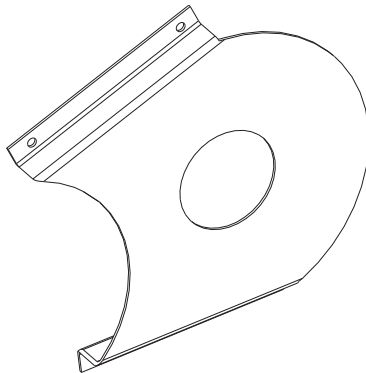

### **Guide Plate**



## **Label Slack Absorber**

The label slack absorber (P/N 1-040061-xx) automatically increases or decreases tension on the media roll as media is pulled into the print module, and keeps the tension as constant as possible for smooth media feed. Use two M4 x 6 mm Torx screws (supplied) to mount the label slack absorber to your printer chassis.

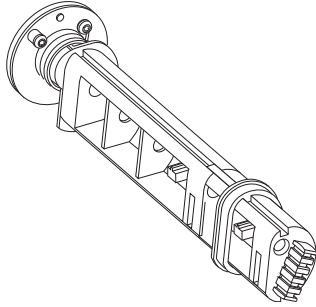

***Label Slack Absorber***

## **About the Parts in Option Kit 3**

Option Kit 3 includes components for self-strip operation.

### **Liner Takeup Unit**

The liner takeup unit (P/N 1-040187-xx) rewinds the spent media liner and is powered by its own stepper motor. Use two M4 x 8 mm Torx screws (supplied) to mount the liner takeup unit to your printer chassis.

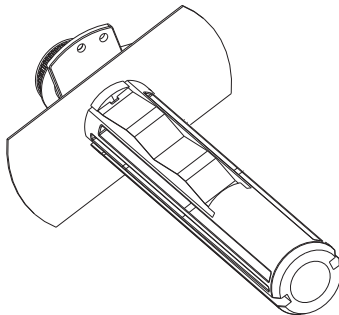

***Liner Takeup Unit***

## **Brace**

The brace (P/N 1-040317-xx) slides onto the liner takeup unit and adds additional support for liner cores that are too large for the takeup hub.

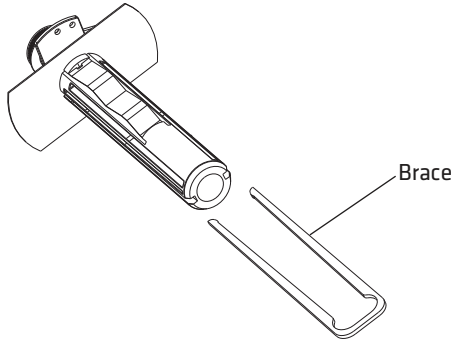

### ***Brace***

## **Break Shaft**

The break shaft (P/N 1-040258-xx) keeps the rewound media away from other nearby components. Use the supplied M4 x 8 mm Torx screw to mount the break shaft on your printer chassis.

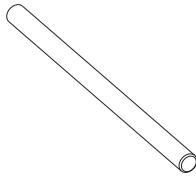

### ***Break Shaft***

## **Stepper Motor**

The stepper motor (P/N 1-040960-9xx) uses a pair of belts (supplied) to drive the liner takeup unit and the liner drive roller in the print mechanism. Use four M4 x 8 mm Torx screws (supplied) to install the stepper motor on the motor mount.

The motor connects to P11 on the driver board.

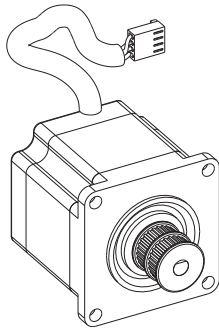

### ***Stepper Motor***

### **Motor Mount**

The motor mount (P/N 1-040105-xx) holds the stepper motor on the printer chassis. Use three M4 x 8 mm Torx screws (supplied) to install the motor mount on the printer chassis.

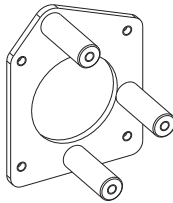

### ***Motor Mount***

### **Belt Stretcher Kit**

When you install the stepper motor and liner takeup unit, use the belt stretcher kit (P/N 1-040239-xx) to install the belts for the liner takeup unit and the liner drive roller in the print module.

## **About the Parts in Option Kit 4**

Option Kit 4 includes chassis parts that are pre-drilled for use with the PX4i and PX6i Print Kit components. This kit includes center, bottom, and back plates as used in the PX4i and PX6i printers.

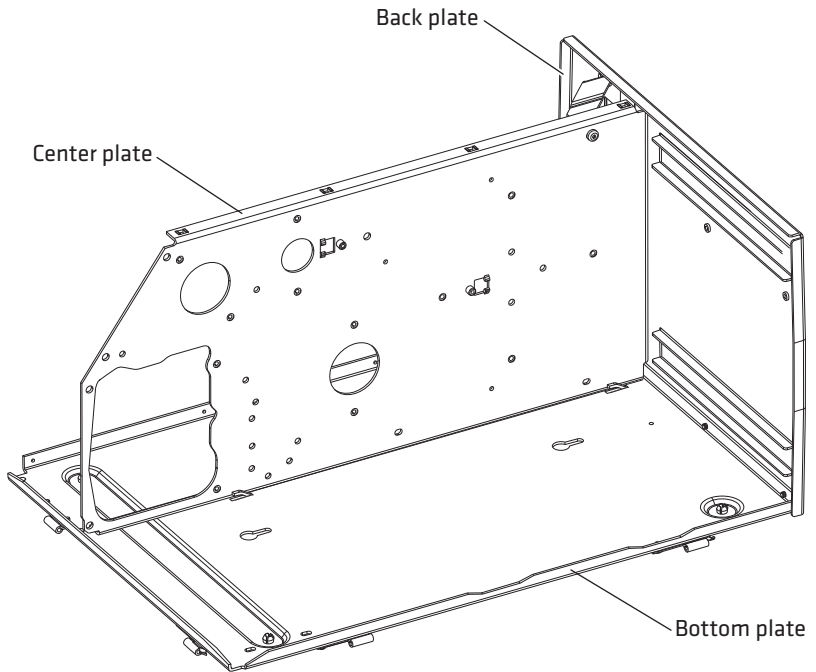

**Option Kit 4 Parts:** Size and appearance of parts varies depending on the kit you ordered.

**Option Kit 4 Parts - Individual Part Numbers**

P/N	Description
1-040173-xx	Bottom plate for 101.6 mm (4 in) printer hardware
1-040173-xx	Bottom plate for 152.4 mm (6 in) printer hardware
1-040184-xx	Center plate
524-123-0xx	Rear plate for 101.6 mm (4 in) printer hardware
524-126-0xx	Rear plate for 152.4 mm (6 in) printer hardware









Worldwide Headquarters  
6001 36th Avenue West  
Everett, Washington 98203  
U.S.A.

tel 425.348.2600

fax 425.355.9551

[www.intermec.com](http://www.intermec.com)

© 2011 Intermec Technologies  
Corporation. All rights reserved.



## PX4i and PX6i Print Kit Integration Guide



P/N 944-633-001