

MC17

Battery Upgrade Kit Installation Instructions

This guide provides instructions for removing the existing battery harness assembly and replacing it with the new upgrade kit (KT-120840-10 or -50). The kit consists of a wiring harness and battery.

Remove Existing Battery Harness

1. Remove screw from screw hole.
2. Slide the battery cover toward the bottom of the handle and then lift.

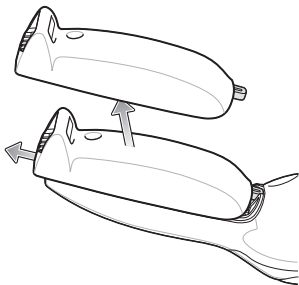

3. Lift battery out of the battery well.
4. Remove the black rubber pad from the battery compartment.

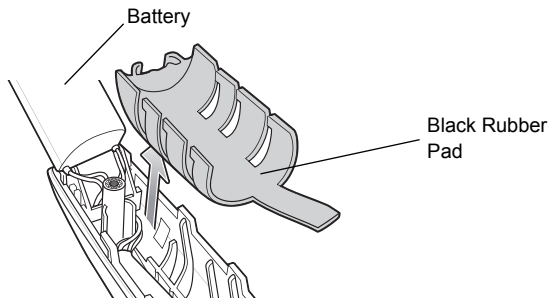

5. Press in the two retaining tabs on both sides of the connector mounting bracket and lift out of the handle.

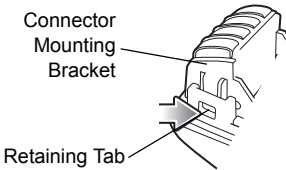

6. Disconnect the harness connector from the printed circuit board (PCB) connector.

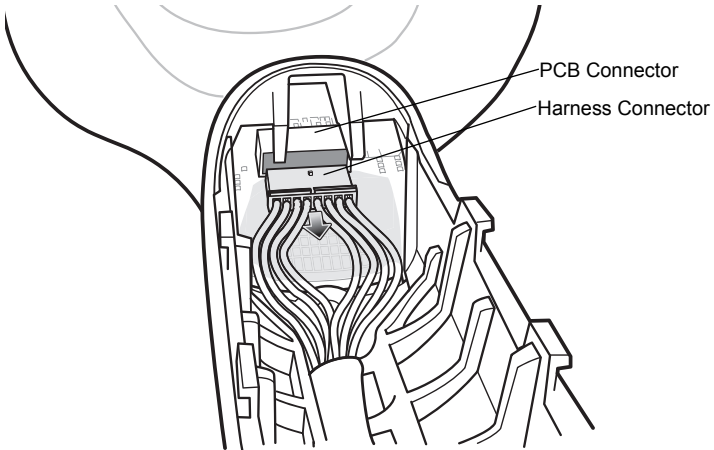

7. Properly discard the old battery and harness assembly.

Install the New Battery Upgrade Kit



Wiring Harness

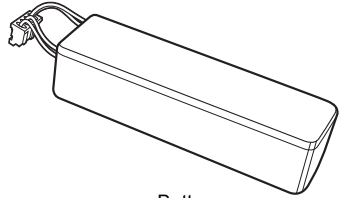

Battery

To install the new wiring harness:

1. Align the wiring harness connector with the connector on the PCB.

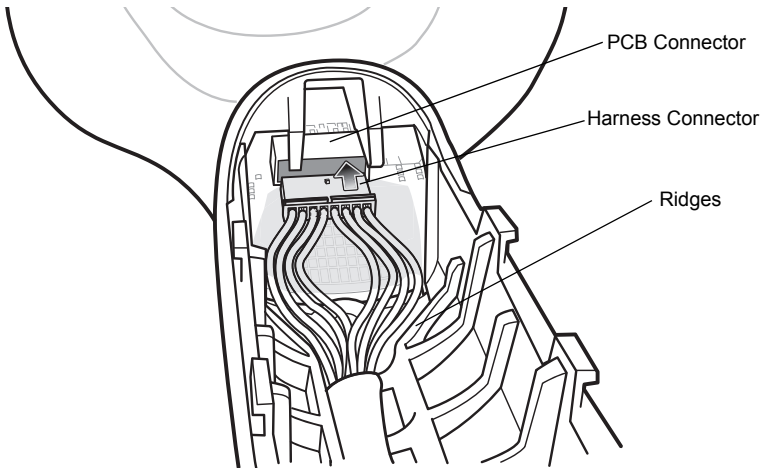

✓ **NOTE** The harness connector is keyed. Ensure that the rib on the connector is facing up.

2. Push the wiring harness connector into the PCB connector. Use a plastic tool to ensure that the harness connector is fully mated with the PCB connector.
3. Ensure all wires stay below the plastic ridges.

- Spread the wires near the connector mounting bracket so that they form a loop around the screw boss when installed. Group the black, blue, light orange and green wires together and the white, dark orange, yellow, brown wires together.

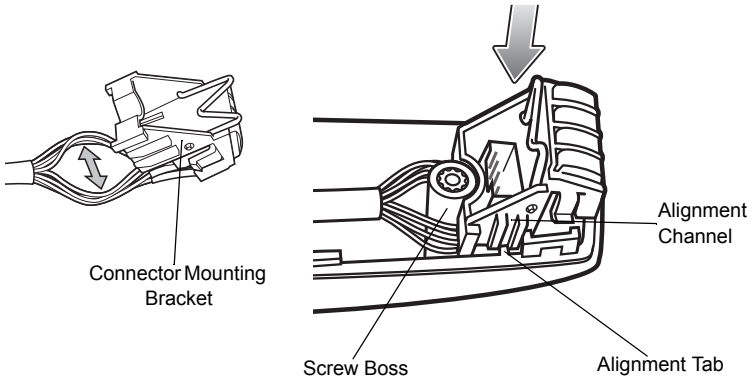

- Slide the harness over the screw boss and align the connector mounting bracket alignment channel with the tab on the handle.
- Push the connector mounting bracket down until it snaps into place.
- Ensure that the wires are spread over the screw boss.
- Replace the black rubber pad into the compartment ensuring that it is lying flat along the bottom of the compartment, with its smoother side facing up, and the rubber "fingers" straddling the screw boss.

To install the new battery:

- Place the battery, rounded side down, in the compartment ensuring that the black rubber pad stays in position. Using a needle nose pliers or tweezers (if necessary), guide the battery cable connector into the female battery connector on the connector mounting bracket.

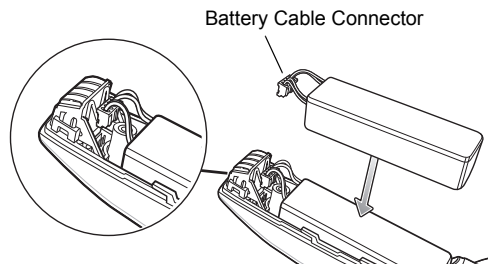

2. Place the battery wires around the screw boss so that they do not interfere when installing the battery cover.
3. Place the wire latch down until just below the top of the screw boss.

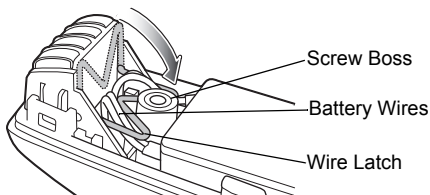

4. Place the battery cover onto the handle and slide it toward the top of the device.

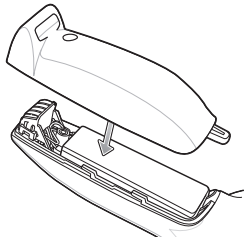

5. Inspect the position of the battery cover with the main housing. Ensure that the battery door is properly positioned by ensuring that the seam between the door and the handle is uniform. If the door is misaligned, remove battery and black rubber pad and re-install.

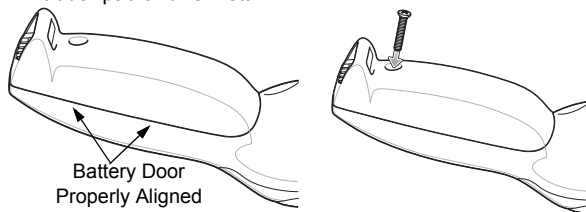

6. Secure the battery cover with the Torx screw using a T8 Torx drive.
7. After installing a new battery, wait approximately one minute before inserting the mobile computer into a cradle.



Waste Electrical and Electronic Equipment (WEEE)

English: For EU Customers: All products at the end of their life must be returned to Zebra for recycling. For information on how to return product, please go to: <http://www.zebra.com/weee>.

Français: Clients de l'Union Européenne : Tous les produits en fin de cycle de vie doivent être retournés à Zebra pour recyclage. Pour de plus amples informations sur le retour de produits, consultez : <http://www.zebra.com/weee>.

Español: Para clientes en la Unión Europea: todos los productos deberán entregarse a Zebra al final de su ciclo de vida para que sean reciclados. Si desea más información sobre cómo devolver un producto, visite: <http://www.zebra.com/weee>.

Deutsch: Für Kunden innerhalb der EU: Alle Produkte müssen am Ende ihrer Lebensdauer zum Recycling an Zebra zurückgesandt werden. Informationen zur Rücksendung von Produkten finden Sie unter <http://www.zebra.com/weee>.

Italiano: per i clienti dell'UE: tutti i prodotti che sono giunti al termine del rispettivo ciclo di vita devono essere restituiti a Zebra al fine di consentirne il riciclaggio. Per informazioni sulle modalità di restituzione, visitare il seguente sito Web: <http://www.zebra.com/weee>.

Português: Para clientes da UE: todos os produtos no fim de vida devem ser devolvidos à Zebra para reciclagem. Para obter informações sobre como devolver o produto, visite: <http://www.zebra.com/weee>.

Nederlands: Voor klanten in de EU: alle producten dienen aan het einde van hun levensduur naar Zebra te worden teruggezonden voor recycling. Raadpleeg <http://www.zebra.com/weee> voor meer informatie over het terugzenden van producten.

Polski: Klienci z obszaru Unii Europejskiej: Produkty wycofane z eksploatacji należy zwrócić do firmy Zebra w celu ich utylizacji. Informacje na temat zwrotu produktów znajdują się na stronie internetowej <http://www.zebra.com/weee>.

Čeština: Pro zákazníky z EU: Všechny produkty je nutné po skončení jejich životnosti vrátit společnosti Zebra k recyklaci. Informace o způsobu vrácení produktu najdete na webových stránkách: <http://www.zebra.com/weee>.

Eesti: EL klientidele: kõik tooted tuleb nende eluea lõppedes tagastada taaskasutamise eesmärgil Zebra'ile. Lisainformatsiooni saamiseks toote tagastamise kohta külastage palun aadressi: <http://www.zebra.com/weee>.

Magyar: Az EU-ban vásárlóknak: Minden tönkrement terméket a Zebra vállalathoz kell eljuttatni újrahasznosítás céljából. A termék visszajuttatásának módjával kapcsolatos tudnivalókért látogasson el a <http://www.zebra.com/weee> weboldalra.

Slovenski: Za kupce v EU: vsi izdelki se morajo po poteku življenjske dobe vrniti podjetju Zebra za reciklažo. Za informacije o vračilu izdelka obiškajte: <http://www.zebra.com/weee>.

Svenska: För kunder inom EU: Alla produkter som uppnått sin livslängd måste returneras till Zebra för återvinning. Information om hur du returnerar produkten finns på <http://www.zebra.com/weee>.

Suomi: Asiakkaat Euroopan unionin alueella: Kaikki tuotteet on palautettava kierrätettäväksi Zebra-yhtiöön, kun tuotetta ei enää käytetä. Lisätietoja tuotteen palauttamisesta on osoitteessa <http://www.zebra.com/weee>.

Dansk: Til kunder i EU: Alle produkter skal returneres til Zebra til recirkulering, når de er udtjent. Læs oplysningerne om returnering af produkter på: <http://www.zebra.com/weee>.

Ελληνικά: Για πελάτες στην Ε.Ε.: Όλα τα προϊόντα, στο τέλος της διάρκειας ζωής τους, πρέπει να επιστρέφονται στην Zebra για ανακύκλωση. Για περισσότερες πληροφορίες σχετικά με την επιστροφή ενός προϊόντος, επισκεφθείτε τη διεύθυνση <http://www.zebra.com/weee> στο Διαδίκτυο.

Malti: Għal klijenti fl-UE: il-prodotti kollha li jkun wasslu fl-aħħar tal-ħajja ta' l-użu tagħhom, iridu jiġu rritornati għand Zebra għar-riciklaġġ. Għal aktar tagħrif dwar kif għandek tirritorna l-prodott, jekk jogħġbok żur: <http://www.zebra.com/weee>.

Slovenski: Za kupce v EU: vsi izdelki se morajo po poteku življenjske dobe vrniti podjetju Zebra za reciklažo. Za informacije o vračilu izdelka obiškajte: <http://www.zebra.com/weee>.

Slovenčina: Pre zákazníkov z krajín EU: Všetky výrobky musia byť po uplynutí doby ich životnosti vrátené spoločnosti Zebra na recykláciu. Bližšie informácie o vrátení výrobkov nájdete na: <http://www.zebra.com/weee>.

Lietuvių: ES vartotojams: visi gaminiai, pasibaigus jų eksploatacijos laikui, turi būti grąžinti utilizuoti į kompaniją „Zebra“. Daugiau informacijos, kaip grąžinti gaminį, rasite: <http://www.zebra.com/weee>.

Latviešu: ES klientiem: visi produkti pēc to kalpošanas mūža beigām ir jānogādā atpakaļ Zebra otrreizējai pārstrādei. Lai iegūtu informāciju par produktu nogādāšanu Zebra, lūdzu, skatiet: <http://www.zebra.com/weee>.

Service Information

If you have a problem using the equipment, contact your facility's Technical or Systems Support. If there is a problem with the equipment, they will contact Zebra Support at: <http://www.zebra.com/support>.

For the latest version of this guide go to: <http://www.zebra.com/support>.



Zebra Technologies Corporation
Lincolnshire, IL U.S.A.
<http://www.zebra.com>

Zebra and the Zebra head graphic are registered trademarks of ZIH Corp. The Symbol logo is a registered trademark of Symbol Technologies, Inc., a Zebra Technologies company.

© 2015 Symbol Technologies, Inc.



72-122988-02 Revision A - February 2015