

MOUNTING BRACKET INSTALLATION GUIDE

CRADLE SETUP

1. Remove the backing from the black rubber pad and place onto the back of the Ten Slot Charging Cradle as shown.
2. Place the power supply into the mounting tabs.
3. Plug the AC line cord into the power supply.
4. Wrap the power supply cord around the cable guides.
5. Plug the power plug into the power port on the cradle.
6. Snap the ferrite into the mounting slot.
7. Place the four mounting bracket tabs into the slots on the cradle.
8. Slide the mounting bracket up until the tabs enter the slots.
9. Secure the mounting bracket to the cradle using the two supplied screws. Torque to 20 kgf-cm (1.45 lbf-ft).

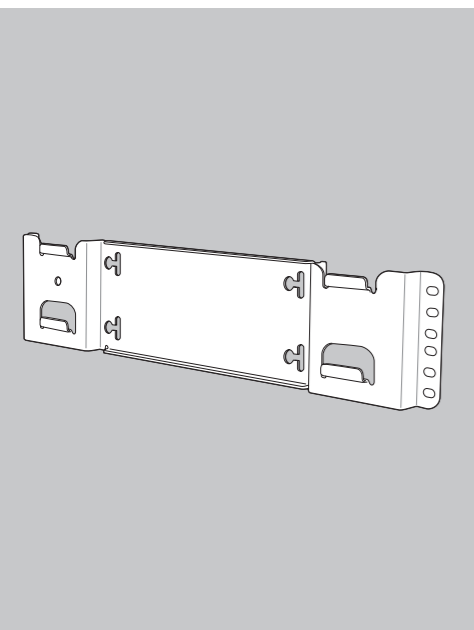
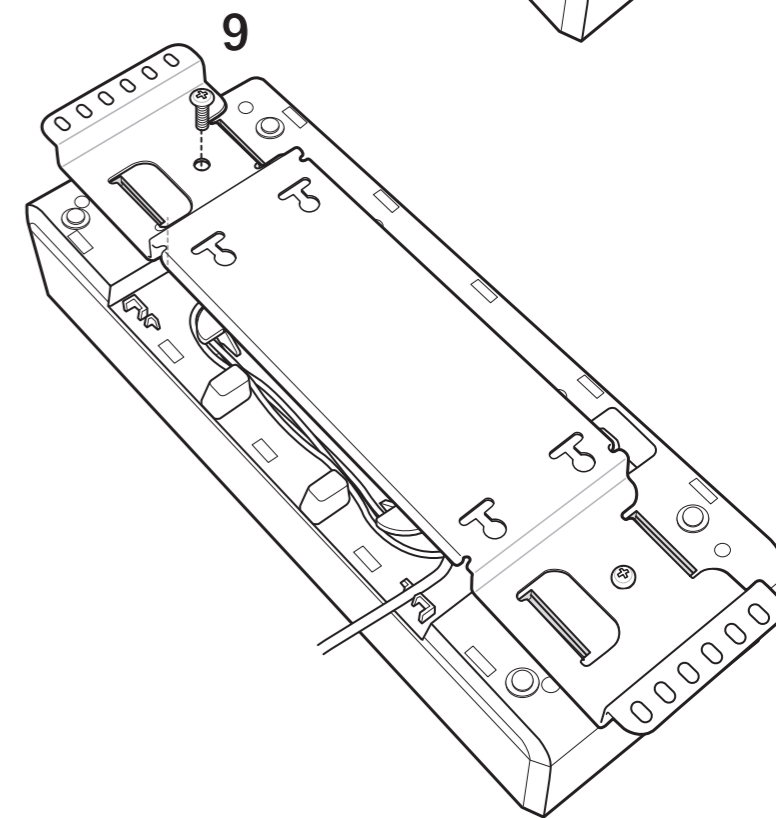
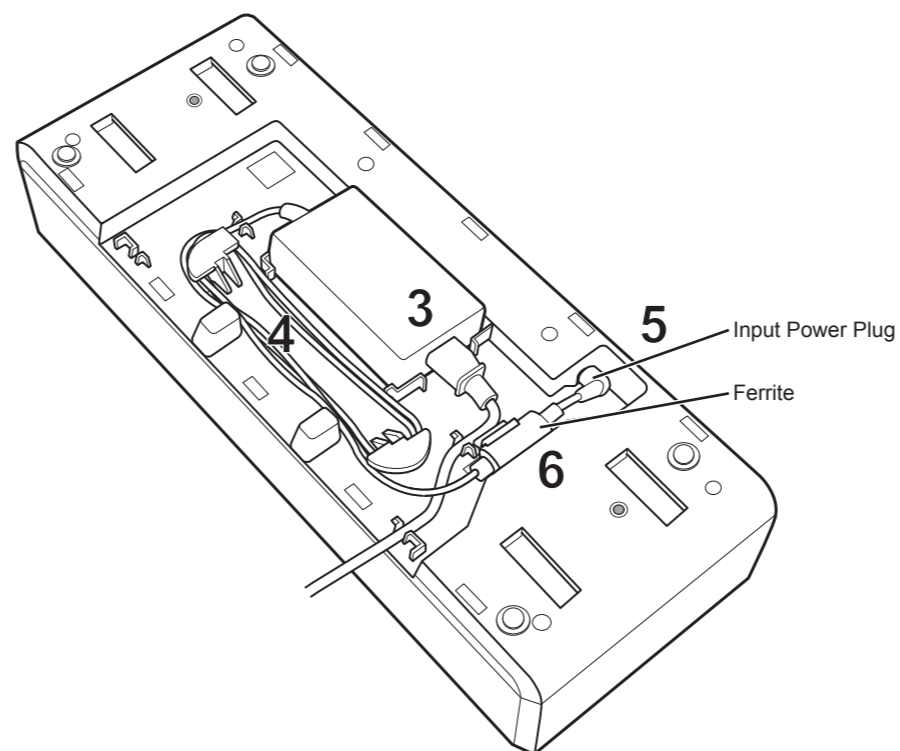
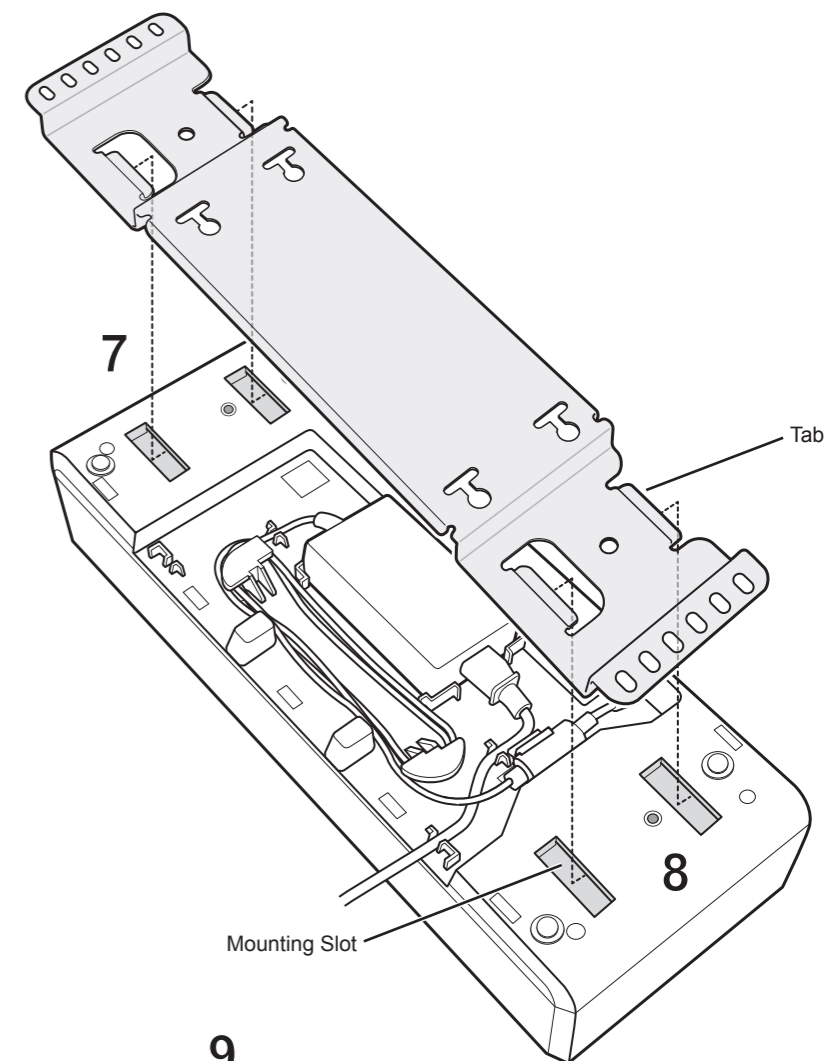
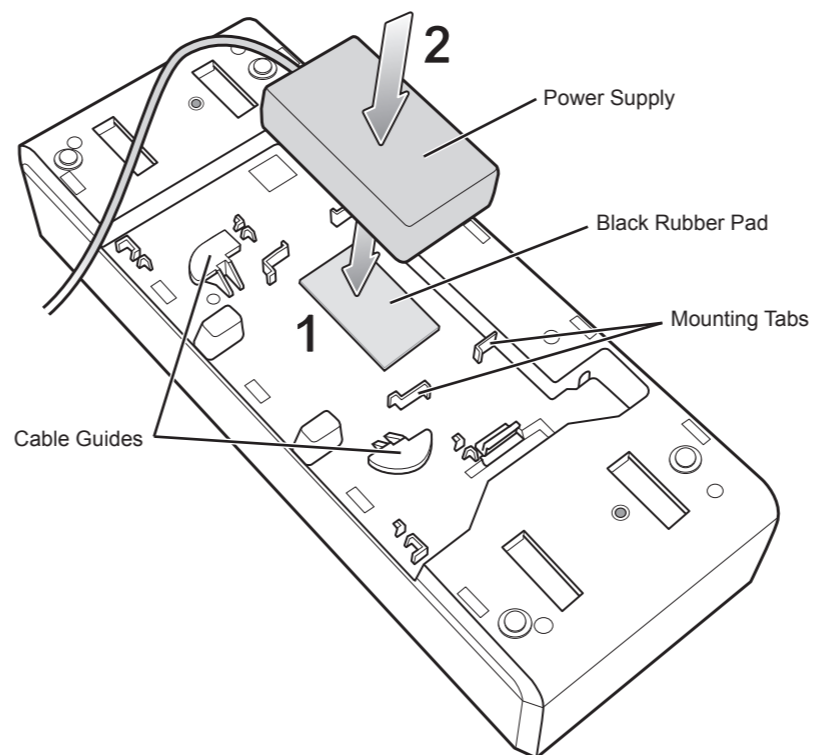

Zebra reserves the right to make changes to any product to improve reliability, function, or design. Zebra does not assume any product liability arising out of, or in connection with, the application or use of any product, circuit, or application described herein. No license is granted, either expressly or by implication, estoppel, or otherwise under any patent right or patent, covering or relating to any combination, system, apparatus, machine, material, method, or process in which Zebra products might be used. An implied license exists only for equipment, circuits, and subsystems contained in Zebra products.



Zebra Technologies Corporation
Lincolnshire, IL U.S.A.
<http://www.zebra.com>

Zebra and the Zebra head graphic are registered trademarks of ZIH Corp. The Symbol logo is a registered trademark of Symbol Technologies, Inc., a Zebra Technologies company.
© 2015 Symbol Technologies, Inc.



WALL MOUNT

CAUTION:

Use mounting hardware (screws and/or anchors) appropriate for the type of wall mounting the bracket onto. The Mount Bracket mounting slots dimensions are 5 mm (0.2 in.). Fasteners must be able to hold a minimum of 4.5 Kg (10 lbs.)

For proper installation consult a professional installer. Failure to install the Wall Mount Bracket properly can possibly result in damage to the hardware.

1. Mark the four screw hole locations and drill holes.
2. Install the four screws and/or anchors into the wall.
3. The screw heads should protrude 2.5 mm (0.01") from the wall.
4. Align the mounting bracket's mounting holes with the screws. Place the bracket/cradle assembly on the screws.
5. Slide the bracket/cradle assembly to the left and down.

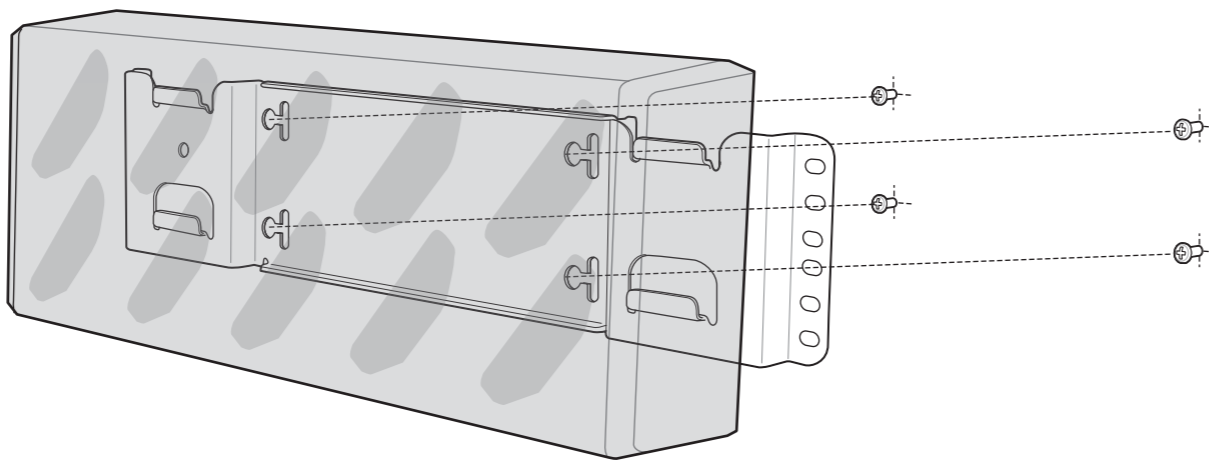
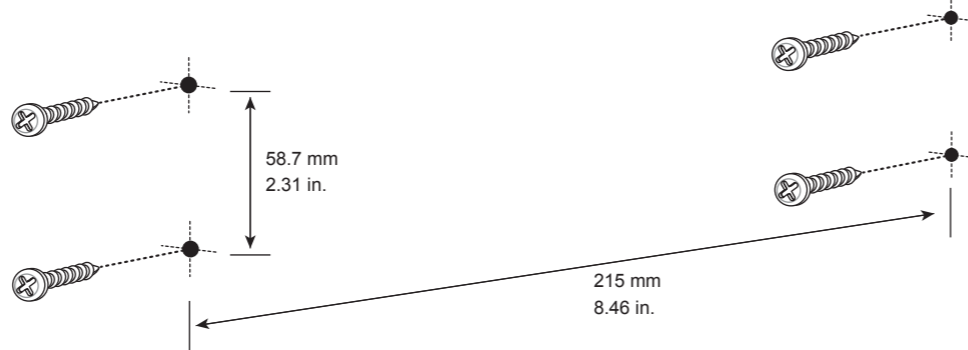

RACK MOUNT

