

M3 ORANGE Snap-On

User Guide



Product Model:
A-SNO-ATYP-060-R00

Compatible Device:
M3 ORANGE

Version 2.2
Released in March 2013

Contents

Copyright and Agreement	3
Notice	4
Warnings and Cautions for Safety. 6	
1. Checklist	8
2. Usage	9
Description	9
Specification	12
Block Diagram	13
3. FAQ and Troubleshoot	14

Charging	14
PC Connection	15
Serial Communications	16
Services and Support	17

Copyright and Agreement in Usage

All contents of this user manual are protected by the copyright laws, and M3 Mobile Co., Ltd. owns all rights related to them.

Any part of this document cannot be copied, reproduced, modified, or translated to other languages without the prior written consent of M3 Mobile.

The contents of this user manual were written based on the “current state” of the product, and the details of this manual are subject to change without the prior notice.

M3 Mobile does not provide any guarantee including the implied guarantee on the product’s characteristics in this user manual and suitability for special purposes, and any other guarantees not limited to them.

Microsoft, Windows, MS Office, Outlook, ActiveSync, Internet Explorer, Windows Logo, and Windows CE, Windows Mobile Logos are registered trademarks or trademarks of Microsoft in the USA or other countries. The license for OEM of Microsoft products was provided by Microsoft Licensing Inc., subsidiary company of Microsoft.

M3 Snap-On is a trademark of M3 Mobile.

All product names and services used in the manual and product are company names, service marks, trademarks, or registered trademarks of the corresponding right owners.

Notice – General Notices

The contents of this user manual were made based on the “current state” of the product, and this manual may contain technical and editing errors or omissions.

When separate application programs are developed and provided by the product providers using the product, refer to the program user’s manual provided by the product providers.

The companies that produce separate application programs besides the basic installation programs must include the contact telephone number for inquiring about these programs on the product, program, or product box separately when distributing the equipment.

M3 Mobile does not guarantee the quality of the programs produced by third party software companies installed after the release from the factory of M3 mobile.

M3 Mobile may request programs from the program manufacturers in order to guarantee the quality of the product to meet the requests of mobile network service providers.

Notice – Revision History

Version 2.2 – March, 2013

- Change address and M3 Mobile technical support webpage

Version 2.1 – July, 2012

- RS232 Port description has been added.
- Contact Detail has been modified.

Version 2.0 – Mar, 2011

- First release of separate user manual for Snap-On.

Version 1.0 – May, 2010

- First release of printed version.

Warnings and Cautions for Safety

Before You Begin

Please read the warnings and cautions for safety carefully before you begin to avoid any damages or accidents. If you are not certain on any information given in this manual, please contact your supplier.

Customer Cautions

If the device is lost or stolen, then immediately report the incident to the service provider.

Refrain from using the device while driving.

When service for the product is required, request services through the designated service center of M3 Mobile.

For inquires about the application programs and other work programs besides the hardware and the basic installation, directly contact the corresponding program manufacturers.

Do not use any battery adapter or accessories other than the designated ones provided with the product.

Free warranty service may not be allowed if failures occur due to unauthorized use or misuse of the product.



Warnings and Cautions for Safety – Cntd.

Cautions in Carrying and Storing

Do not use the product in high temperature or high humidity environments as this may quickly cause damage to the product.

The product was designed to be suitable for work environments, but avoid impacts or dropping the product. This may cause fatal damage to the product.

Fully charge the battery before using the product for the first time.

Do not modify the product

Do not try to modify the product by any means.

Modifications may cause fire, injury, electric shock, or serious damage to the equipment and users.

The warranty service is not provided for troubles due to unauthorized modification.

1. Checklist

Thank you for selecting M3 Snap-On. This guide will help you on basic usage of the product. Please check if all the contents shown below are nearby for use. Power supply is needed for charging and data communication.

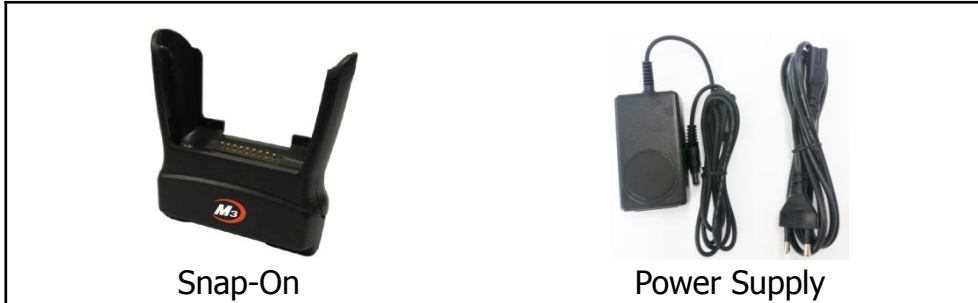

Snap-On

Power Supply

If you don't have everything, contact your supplier immediately.
Serial cables is not provided from M3 Mobile.



Caution

Please use the correct power supply provided by M3 Mobile. Compatibility with other power supply source is not guaranteed.

2. Usage – Description

A-SNO-ATYP-060-R00 is the M3 Mobile's optional accessory that is purchased separately with PDA.

Description

Refer to next images for Snap-On parts and descriptions.

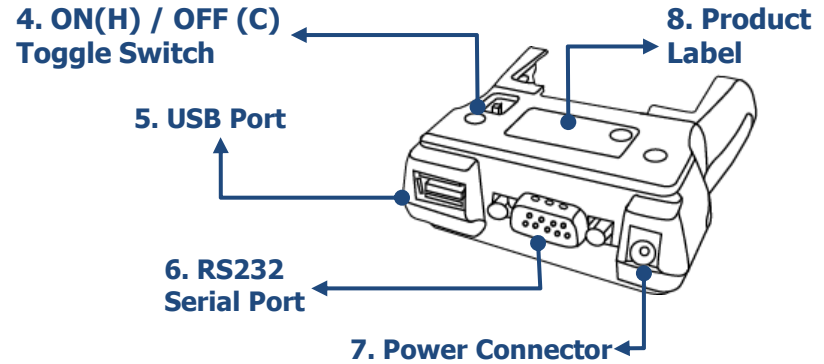
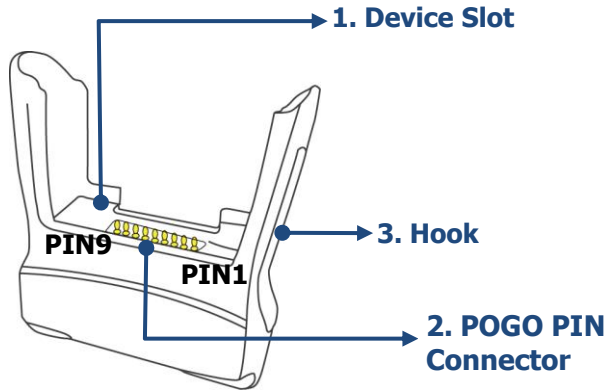

2. Usage – Description continued.

- 1. Device Slot** – A PDA slides into the slot for charging, data transfer or ActiveSync connection.
- 2. POGO Pin Connector** – Used for data communication with PDA such as ActiveSync.

1	2	3	4	5	6	7	8	9
USB D-	USB D+	USB VBUS	COM6_DET (N/A)	RXD (N/A)	TXD (N/A)	USB ID	GND	5V

- 3. Hook** – Press and hold to slides out PDA from Snap-On.
- 4. ON (H) / OFF (C) Toggle Switch**

Snap-On Type	A-SNO-ATYP-060-R00
Switch ON	- Serial communication (Com8) is possible. - The terminal goes into USB Host mode.
Switch OFF	- The terminal is in USB Client mode, thus ActiveSync with a PC is possible.

- 5. USB Port*** – USB host or client can be used. Make sure the switch is switched to proper side for use.

2. Usage – Description continued.

6. RS232 Serial Port – This RS232 port enables serial communication. Switch must be at 'ON (H)'.

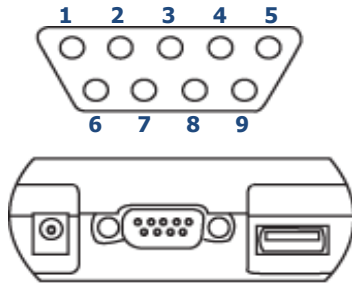

1	2	3	4	5	6	7	8	9
N/A	RXD	TXD	N/A	GND	N/A	RTS	CTS	N/A

7. Power Connector – AC power supply connector. Make sure the authentic power supply is used. DC Jack type connector is used.

8. Product Label – Indicates information such as Model, Input and S/N. The serial number can be used to distinguish between Snap-On types.



Caution

- **Do not use the Vehicle Cigar Jack** to supply power to Snap-On. It can cause critical damage to the PDA due to the different voltage.
- When switching between ON (H) and OFF (C), the PDA must be removed from the device slot.

2. Usage – Specification

Model		A-SNO-ATYP-060-R00	
Compatible PDA(s)		M3 ORANGE	
Adapter Input		AC 100 ~ 240V, 50 ~ 60Hz	
Adapter Output		DC 5V / 3A	
Power Connector		DC Jack Type	
USB	Host	Supported (Switch ON)	N/A
	Client	Supported (Switch OFF)	Supported (Switch OFF)
Serial Port		Com8 is used (Switch ON)	
Ethernet Port		N/A	
Snap-On / PDA Connector		9 PIN POGO Connector. Refer to '2. Usage – Description No.2 POGO Pin Connector' for pin I/O information.	

2. Usage – Block Diagram

A-SNO-ATYP-060-R00

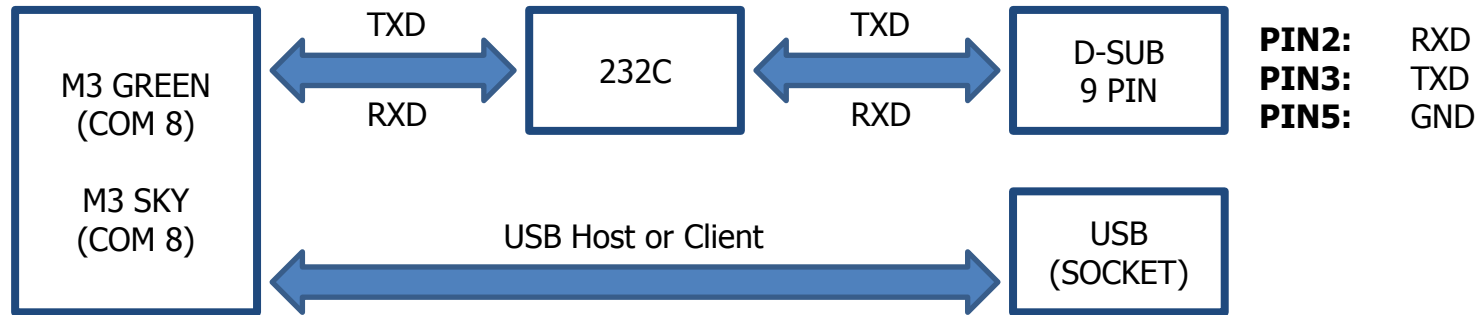

Switch ON: Serial communication and USB Host can be used.

Switch OFF: USB Client is possible.

3. FAQ and Troubleshoot – Charging

This chapter provides frequently asked questions and its corresponding answers.

Charging

Q1. How to charge PDA using the Snap-On?

Step 1. Plug in the AC adapter plug to wall jack and DC jack to power connector of Snap-On.

Step 2. Insert the PDA to device slot to start charging the PDA.

Q2. Charging Status

Charging status of the PDA is indicated by LEDs.

LED on upper left corner indicates the charging status of the battery attached to the PDA.



Caution

1. Use the correct AC adapter with 5V, 3A output provided by M3 Mobile.
2. Incongruent change of battery can cause the explosion.
3. When attached battery is completely discharged, plug charger to main body, then reset the device to check if the screen is back on. Leave at least for 10 min in charging state before use.

3. FAQ and Troubleshoot – PC Connection

PC Connection

Q1. How to connect to PC.

Snap-On supports charging and USB connection. You must have **Microsoft ActiveSync** or **Windows Mobile Device Manager** (for Windows Vista and 7) installed.

Step 1. Switch ON (H)/OFF (C) toggle switch to **OFF(C)**.

Step 2. Supply power to the Snap-On using the proper AC adapter.

Step 3. Connect PC and the Snap-On using the USB cable.

Step 4. Insert the PDA to the device slot. Your PC will automatically detect the new device.

Q2. PDA is not recognized in ActiveSync or Mobile Device Center.

A2-1. Check if the USB cable is properly connected on both sides.

A2-2. Check if ON (H)/OFF (C) toggle switch is switched to **OFF(C)**.

A2-3. If switch is changed to **OFF(C)** while PDA is in the cradle, remove the PDA from the slot then slide in again.

A2-4. Check if the ActiveSync or Mobile Device Manager on your PC is compatible with the OS of the PDA. For more information, visit <http://www.microsoft.com/canada/windowsmobile/wm07/devicecenter/troubleshooting.mspx>

3. FAQ and Troubleshoot – Serial Comms.

Serial Communication

Q1. Cannot use Serial communication through Snap-On. What should I check?

A1-1. Check if the serial cable is properly connected on both sides.

A1-2. Make sure the ON (H)/OFF (C) toggle switch is switched to **ON(H)**.

A1-3. Check if necessary driver(s) are installed on the PC or equivalent hardware.

Q2. Can Serial communication and ActiveSync be used simultaneously?

A2-1. No. Since ActiveSync requires 'Client Mode' on the Snap-On and Serial communication requires 'Host Mode', it cannot be used at the same time.

Services and Support

Should you require any services or technical support on M3 Mobile's products, contact your supplier or visit M3 Mobile technical support webpage <http://itc.m3mobile.net>. Desired or relevant manuals can be downloaded from **Knowledge Center** or **FAQ** in technical support webpage.

For DOA or RMA, please send the defective product to suitable address **AFTER** consulting the supplier.

M3 Mobile Co., Ltd.

Headquarter

M3 Bldg., 735-45,
Yeoksam-Dong, Gangnam-Gu,
Seoul, 135-080, Korea
Tel: +82 2 574 0037(Ext.4) Fax: +82 2 556 0155

Service Center

Chun-ui Techno Park 201-610,
202, Chun-ui Dong, Won-Mi gu, Buchoen,
Gyeonggi Do, Korea , 420-857
Tel: +82 32 623 0037 Fax: +82 32 655 0884

Thank you for choosing M3 Mobile's product!